

# **FFM100**

# **Fuel Flow Monitor**

## **User's Manual**

**Revision 1.7**

**Copyright © 2026 Maretron, now part of Teledyne – All rights reserved**

**Maretron**  
**120 Intracoastal Pointe Drive**  
**Jupiter, FL 33477 USA**  
**Toll Free: +1 (866) 550-9100**  
**Phone: +1 (603) 324-7900**  
**[support@maretron.com](mailto:support@maretron.com)**  
**<http://www.maretron.com>**

**Maretron Manual Part #: M003010**

## Revision History

<b>Revision</b>	<b>Description</b>
1.0	Release for Review
1.1	Public Release
1.2	Corrected formatting problems in certain figures Added notes about tamper-proof silicone seals on sensor screws Added information about location of sensors
1.3	Added information about configuration tools Modified troubleshooting guide Added Maretron Proprietary PGN's for fluid types other than fuel and extended range on trip volume
1.4	Fixed formatting issue in PGN table Updated part numbers of fluid flow sensors and added M8AR and M16AR Added information on flow and volume instance and label configuration Added information on proprietary PGNs Added diagram of fluid flow sensor plumbing with bypass valves
1.5	Added installation general requirements and statement of responsibility to introduction Re-arranged Figure 'Diesel Fuel Rate Measurement Fluid Flow Sensor Locations' Added supplemental information to the sensor selection segment Added troubleshooting guide entries
1.6	Updated Fuel Flow Sensor Selection Chart for Diesel Applications
1.7	Updated company profile and contact details Revised document format Updated Warrant information Added Support QR Codes Miscellaneous verbiage updates

## Table of Contents

1	General.....	1
1.1	Introduction .....	1
1.2	Prerequisites .....	1
1.3	Firmware Revision .....	1
1.4	Features .....	1
1.5	FFM100 Accessories .....	2
1.6	Quick Install .....	2
1.7	Theory of Operation .....	2
1.7.1	Operating Modes .....	2
1.7.2	Sensor Accuracy .....	2
1.7.3	Diesel Fuel Flow Measurement .....	4
1.7.4	Temperature Compensation .....	5
1.7.5	Fluid Flow Sensor Selection .....	5
1.7.6	Accuracy of Diesel Fuel Flow Measurement .....	7
1.7.7	Choosing a Fluid Flow Sensor Mounting Location .....	7
2	Installation .....	8
2.1	Unpacking the Box .....	8
2.2	Choosing a Mounting Location .....	8
2.3	Mounting the FFM100 .....	8
2.4	Mounting & Connecting the Fluid Flow Sensor(s) to the vessel .....	9
3	Connecting the Fluid Flow Sensor(s) to the FFM100 .....	10
3.1.1	Fluid flow sensor Connections .....	10
3.1.2	NMEA 2000 Connection .....	11
4	Configuring the FFM100 .....	12
4.1	Advanced Configuration .....	13
4.1.1	Configuring Device Instance .....	13
4.1.2	Configuring Channel #0 Installation Orientation .....	13
4.1.3	Configuring Channel #1 Installation Orientation .....	13
4.1.4	Configuring Channel #0 Allow Negative Flow .....	13
4.1.5	Configuring Channel #1 Allow Negative Flow .....	13
4.1.6	Configuring Differential Mode Allow Negative Flow .....	13
4.1.7	Configuring Installation Description .....	14
4.1.8	Configuring NMEA 2000 PGN Enable/Disable .....	14
4.1.9	Restoring Factory Default Settings .....	14
4.2	Configuring the Device Label .....	14
4.3	Configuring the Operating Mode .....	14
4.4	Configuring Channel #0 .....	14
4.4.1	Enabling/Disabling Channel #0 .....	14
4.4.2	Configuring Channel #0 Engine Instance .....	14
4.4.3	Configuring Channel #0 Engine Label .....	15
4.4.4	Configuring Channel #0 K-factor .....	15
4.4.5	Configuring Channel #0 Data Damping Period .....	15
4.4.6	Resetting the Total Volume Recorded for Channel #0 .....	15
4.4.7	Configuring Channel #0 Temperature Instance .....	15
4.4.8	Configuring Channel #0 Temperature Source .....	15
4.4.9	Configuring Channel #0 Temperature Label .....	15
4.4.10	Configuring Channel #0 Flow Instance .....	15
4.4.11	Configuring Channel #0 Flow Label .....	15
4.4.12	Configuring Channel #0 Volume Instance .....	16
4.4.13	Configuring Channel #0 Volume Label .....	16

4.5	Configuring Channel #1 .....	16
4.5.1	Enabling/Disabling Channel #1 .....	16
4.5.2	Configuring Channel #1 Engine Instance .....	16
4.5.3	Configuring Channel #1 Engine Label.....	16
4.5.4	Configuring Channel #1 K-factor .....	16
4.5.5	Configuring Channel #1 Temperature Coefficient .....	16
4.5.6	Configuring Channel #1 Data Damping Period.....	17
4.5.7	Resetting the Total Volume Recorded for Channel #1 .....	17
4.5.8	Configuring Channel #1 Temperature Instance.....	17
4.5.9	Configuring Channel #1 Temperature Source .....	17
4.5.10	Configuring Channel #1 Temperature Label.....	17
4.5.11	Configuring Channel #1 Flow Instance.....	17
4.5.12	Configuring Channel #1 Flow Label .....	17
4.5.13	Configuring Channel #1 Volume Instance .....	18
4.5.14	Configuring Channel #1 Volume Label.....	18
5	Maintenance.....	18
6	Troubleshooting.....	19
6.1	Troubleshooting Guide Table.....	19
6.2	Troubleshooting Guide Supplement.....	20
6.2.1	M1AR – M16AR Oval Gear Flow Sensor Operating Principle .....	20
6.2.2	M1AR - M16AR Oval Gear Troubleshooting .....	20
6.2.3	FFM100 Differential System Troubleshooting .....	20
7	Technical Specifications .....	21
8	Technical Support.....	22
9	Installation Template .....	23
10	Maretron (2 Year) Limited Warranty .....	24

## **Table of Figures**

Figure 1	– M1AR and M2AR Accuracy and Pressure Loss .....	3
Figure 2	– M4AR Typical Accuracy and Pressure Loss .....	3
Figure 3	– M8AR and M16AR Typical Accuracy and Pressure Loss .....	4
Figure 4	– Diesel Fuel Rate Measurement Fluid Flow Sensor Locations.....	5
Figure 5	– Fluid Flow Sensor Selection Chart for Diesel Engine Applications .....	6
Figure 6	– Mounting the FFM100.....	8
Figure 7	– Fluid Flow Sensor Installation with Bypass and Isolating Valves .....	9
Figure 8	– Fluid flow sensor Connection Diagram .....	11
Figure 9	– NMEA 2000 Connector .....	11
Figure 10	– Troubleshooting Guide.....	19
Figure 11	– Mounting Surface Template.....	23

## **Table of Appendices**

Appendix A	– NMEA 2000® Interfacing.....	A1
------------	-------------------------------	----

## 1 General

### 1.1 Introduction

Congratulations on your purchase of the Maretron Fuel Flow Monitor (FFM100). Maretron has designed and built your monitor to the highest standards for years of reliable, dependable, and accurate service.

Maretron's Fuel Flow Monitor (FFM100) is used to adapt up to two positive displacement fluid flow sensors to the NMEA 2000® network (fluid flow sensors sold separately). This allows you to observe engine fuel usage on a vessel where there are NMEA 2000 compatible displays. With the appropriate sensor, the FFM100 reports fuel flow rate for diesel engines or gasoline engines and flow rate for other compatible fluid types as well such as hydraulic oil, coolants, and clean water.

The Maretron FFM100 is designed to operate within the harsh demands of the marine environment. However, no piece of marine electronic equipment can function properly unless installed, calibrated, and maintained in the correct manner. Please read carefully and follow these instructions for installation, calibration, and usage of the Maretron FFM100 in order to ensure optimal performance.

### 1.2 Prerequisites

There are general and specific prerequisites for the application of the FFM100 solution to fuel flow monitoring. A beforehand understanding of fuel systems and fuel piping is recommended.

Your engine(s) require a clean and consistent fuel supply with a fuel pressure requirement. This CANNOT be ignored in any circumstances. The insertion of the fuel flow sensors into the fuel system will introduce an additional pressure drop in the fuel system as the fuel passes through the sensors. Please refer to Figure 1, Figure 2, and Figure 3 for details as to the magnitude of this pressure drop. You need to ensure that with this additional pressure drop, your fuel system can still supply the engine with fuel at the engine's required flow rate at maximum RPM to avoid starving the engine of fuel under this condition. This is governed by the choice of fuel line diameter and length as well as the fuel pump capacity.

The installer of Maretron's fuel flow monitoring system is the only party responsible for the performance of the monitoring system and the performance of the engine(s) fuel system. Maretron is not responsible for faulty design or improper installation practices.

Maretron cannot advise on the specific fuel system requirements of any marine engine. These requirements need to come from the engine manufacturer and any calculations or necessary vessel modifications must be undertaken by the installer or contracted parties to ensure compliance with the engine manufacturer's requirements.

### 1.3 Firmware Revision

This manual corresponds to FFM100 firmware revision 1.2.2.1.

### 1.4 Features

The Maretron FFM100 has the following features:

- NMEA 2000 interface
- Adapts up to two fluid flow sensors to the NMEA 2000 network

- Each channel independently programmable to match fluid flow sensor characteristics
- The FFM100 can be programmed to measure a differential flow rate using two fluid flow sensors (supply and return flow for diesel engines) or two completely independent flow rates.

## **1.5 FFM100 Accessories**

Maretron offers the following accessories for the FFM100:

- M1AR Fluid Flow Sensor 2 to 100 LPH (0.53 to 26.4 GPH)
- M2AR Fluid Flow Sensor 25 To 500 LPH (6.6 to 132 GPH)
- M4AR Fluid Flow Sensor 180 To 1500 LPH (48 to 396 GPH)
- M8AR Fluid Flow Sensor 480 To 4200 LPH (127 to 1110 GPH)
- M16AR Fluid Flow Sensor 600 To 6000 LPH (159 to 1585 GPH)

## **1.6 Quick Install**

Installing the Maretron FFM100 involves the following steps. Please refer to the individual sections for additional details.

1. Unpack the Box (Section 2.1)
2. Choose a Mounting Location (Section 2.2)
3. Mount the FFM100 (Section 2.3)
4. Mount the Flow Sensors and Connect Fluid Lines (Section 2.4)
5. Connect the Flow Sensors to the FFM100 (Section 3.1.1)
6. Connect the FFM100 to the NMEA 2000 network (Section 3.1.1)
7. Configure the FFM100 (Section 4)

## **1.7 Theory of Operation**

The FFM100 operates by using positive displacement fluid flow sensors. These sensors are volumetric (they measure the volume of fluid passing through them as opposed to the mass of the fluid). The fluid flow sensors are compatible with diesel, gasoline (petrol fuel), lubricating oil, hydraulic fluid, and water.

### **1.7.1 Operating Modes**

The FFM100 can operate in one of two user-selectable operating modes:

- 1) Differential Flow Rate – this mode is used for diesel engines that recirculate unused fuel back into the fuel tank. These engines will have separate supply and return fuel lines. In this mode, Channel 0 must be connected to the fluid flow sensor on the supply fuel line, and Channel 1 must be connected to the fluid flow sensor on the return fuel line.
- 2) Two Independent Flow Rates – the FFM100 can measure flow rates from two independent sources: for example, a water flow rate on one channel and a gasoline fuel flow rate on another channel.

### **1.7.2 Sensor Accuracy**

The M1AR, M2AR, M4AR, M8AR, and M16AR fluid flow sensors use positive displacement technology and are accurate over a wide flow range.

Please refer to Figure 1 below for a chart detailing typical accuracy and pressure loss versus flow rate for the M1AR and M2AR fluid flow sensors.

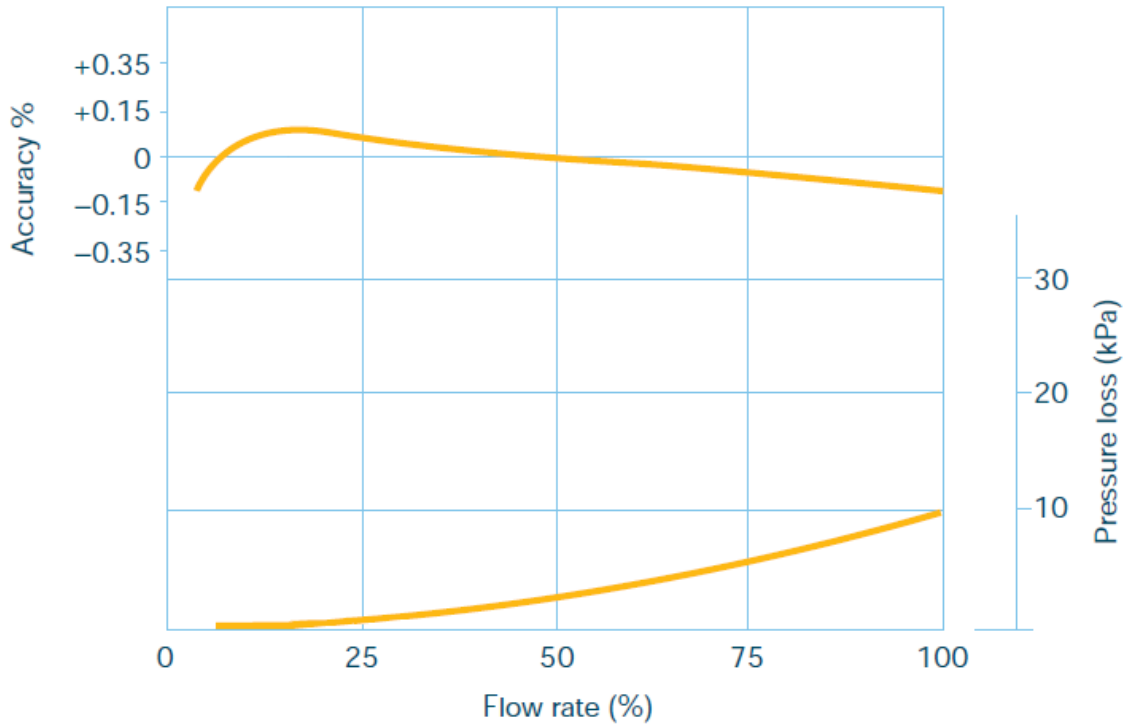

**Figure 1 – M1AR and M2AR Accuracy and Pressure Loss**

Please refer to Figure 2 below for a chart detailing typical accuracy and pressure loss versus flow rate for the M4AR fluid flow sensor.

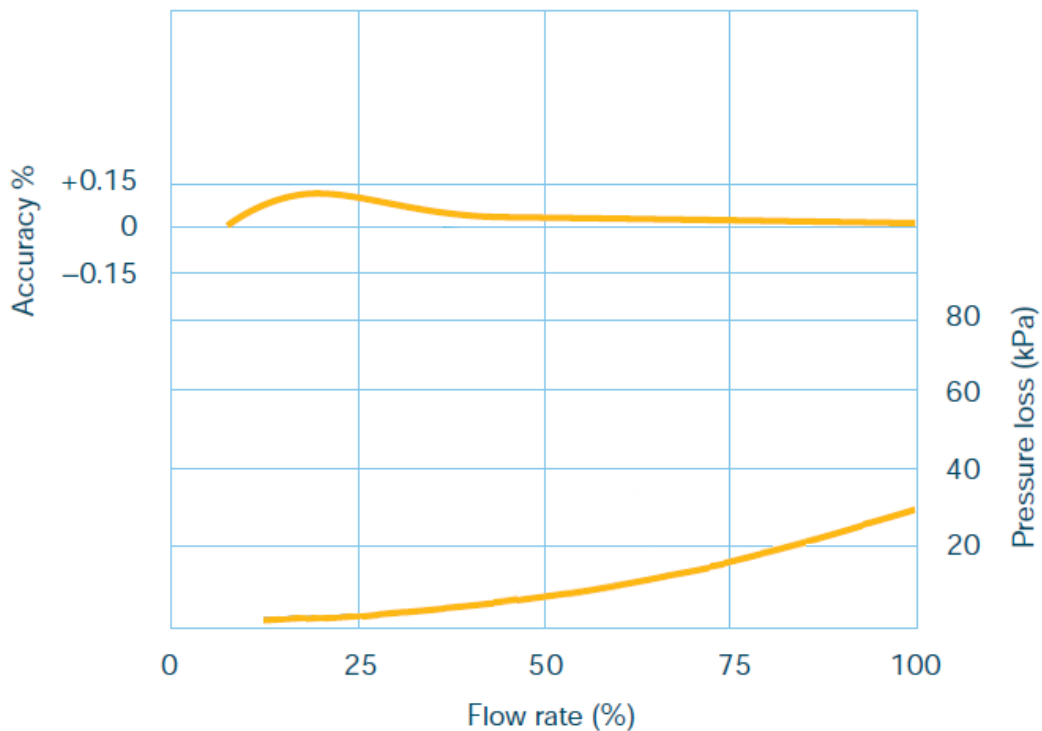

**Figure 2 – M4AR Typical Accuracy and Pressure Loss**

Please refer to Figure 3 below for a chart detailing typical accuracy and pressure loss versus flow rate for the M8AR and M16AR fluid flow sensors.

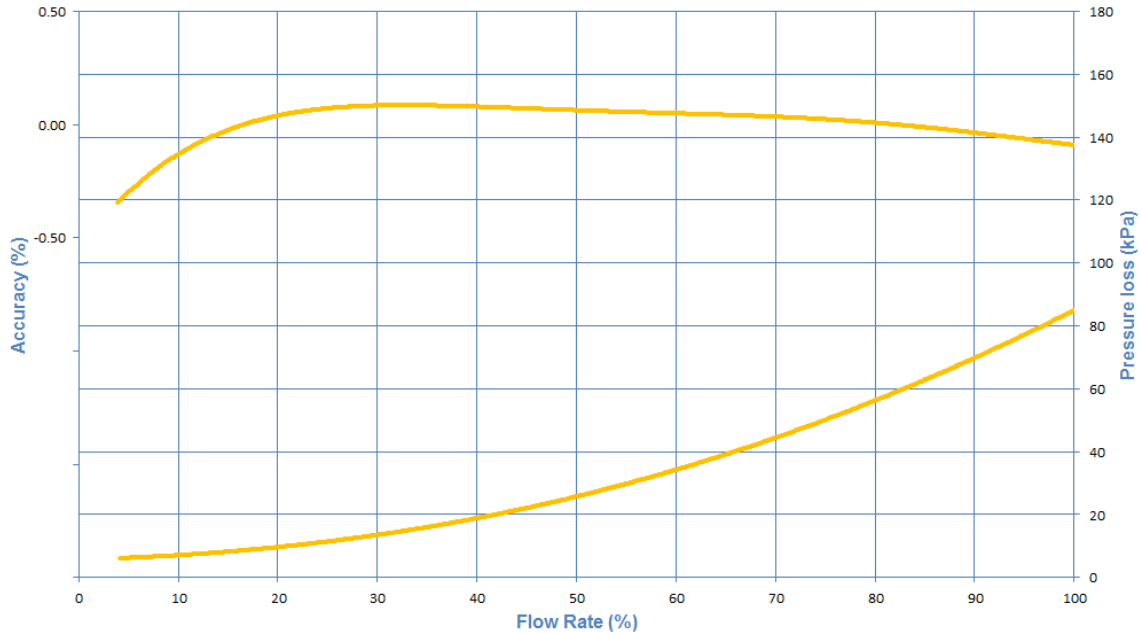

**Figure 3 – M8AR and M16AR Typical Accuracy and Pressure Loss**

### 1.7.3 Diesel Fuel Flow Measurement

Most diesel engines do not use all of the fuel that is supplied to them by the fuel pump via the supply line. A portion of the fuel is consumed by the engine, but the majority of the fuel is used for cooling the injection system and returned to the fuel tank via the return line.

For diesel engines, the FFM100 will operate in its differential mode, and will measure the net fuel consumption of these engines by separately measuring the fuel sent to the engine via the supply line and the fuel returned to the fuel tank from the engine via the return line. The difference between these two readings is the fuel consumption of the engine. Please refer to Figure 4 below for a system diagram demonstrating the location of the supply and return fluid flow sensors in a diesel fuel system.

Note: When wiring Fluid Flow Sensors to FFM100 Module for the application of fuel differential measurement for diesel engines, the fuel supply sensor must be wired to 'Channel 0' of the FFM100 module.

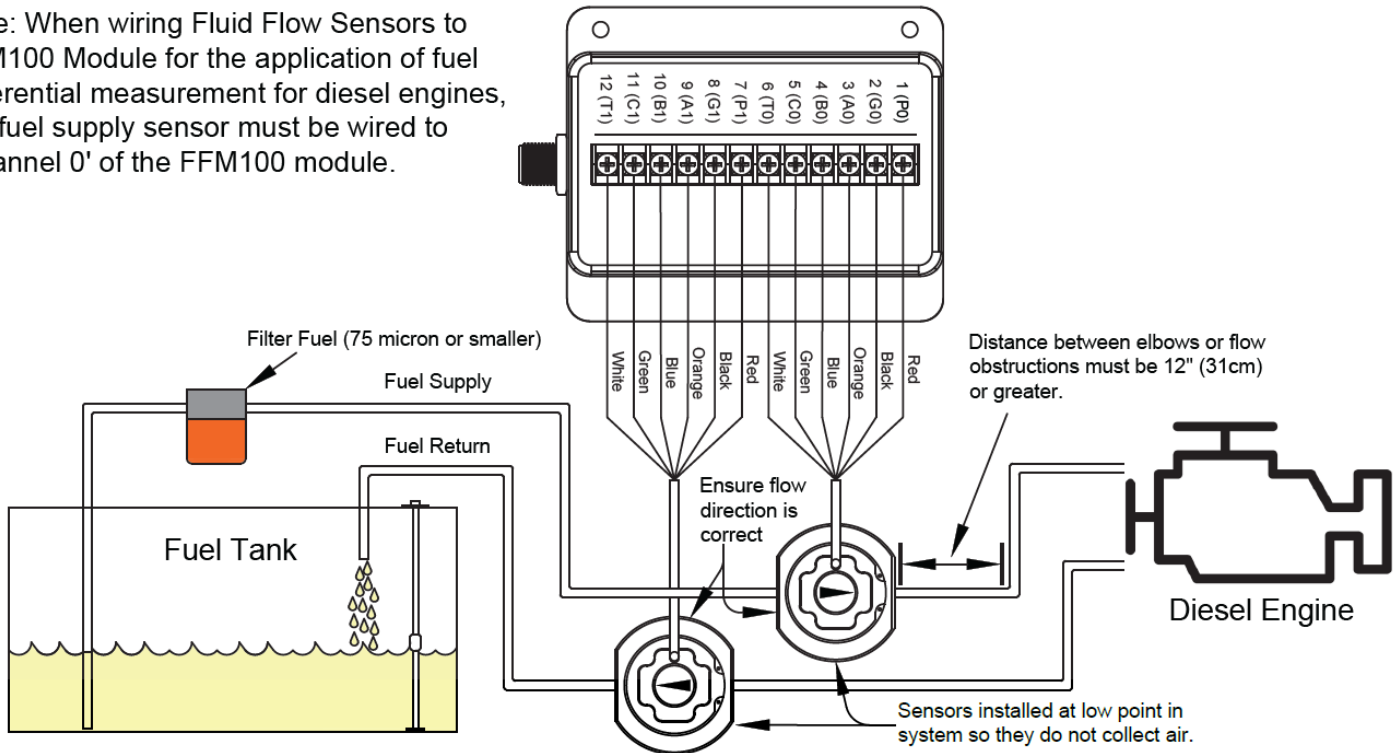

**Figure 4 – Diesel Fuel Rate Measurement Fluid Flow Sensor Locations**

## 1.7.4 Temperature Compensation

The task of computing fuel consumption for a diesel engine is further complicated by the following two factors:

- 1) Diesel fuel expands when heated
- 2) Diesel fuel is heated as it passes through the engine

When using volumetric sensors such as positive displacement sensors or turbine flow sensors, simply subtracting the return flow rate from the supply flow rate without taking these factors into account will result in the fuel consumption being underestimated. In fact, without compensating for temperature, if the engine consumes no fuel, the return fuel flow rate is greater than the supply fuel rate, since the fuel is expanded by the engine's heat as it passes through the injection system.

The M1AR, M2AR, M4AR, M8AR, and M16AR fluid flow sensors feature integrated temperature sensors, so that the temperature of both the supply and return fuel is sensed and used in real time by the FFM100 to compensate for the expansion of the fuel due to the increase in temperature, for the most accurate possible fuel flow measurement.

## 1.7.5 Fluid Flow Sensor Selection

The fluid flow sensors must be sized to accommodate the flow rate range of fluid flowing through the sensor. The table in Figure 5 below shows the minimum and maximum fluid flow rates that can be sensed by each fuel flow sensor and approximate engine power ranges for each fuel flow sensor type for engine fuel measuring applications.

For engine fuel measuring applications, the fluid flow sensor must be sized to accommodate the flow rate range of fuel that will flow through the sensor throughout the engine's RPM range. If too small a fluid flow sensor is used, excessive back pressure will occur through the sensor(s) and the sensor may wear prematurely. If too large a fluid flow sensor is used, the sensor may not accurately measure the fuel rate.

<b>Fluid Flow Sensor</b>	<b>Flow Rate Range</b>	<b>Approximate Engine Power Range (see warning above)</b>
M1AR	0.53 to 26.4 GPH 2 to 100 LPH	20 to 200 HP 14.9 to 149 kW
M2AR	6.6 to 132 GPH 25 to 500 LPH	200 to 1000 HP 149 to 746 kW
M4AR	48 to 396 GPH 180 to 1500 LPH	1000 to 3000 HP 746 to 2237 kW
M8AR	127 to 1110 GPH 480 to 4200 LPH	3000 to 8400 HP 2237 kW to 6266 kW
M16AR	159 to 1585 GPH 600 to 6000 LPH	8400 to 12000 HP 6266 kW to 8952 kW

**Figure 5 – Fluid Flow Sensor Selection Chart for Diesel Engine Applications**

For a differential fuel flow measurement (considering both supply and return measurements for accurate fuel consumption measurement) which is used for measuring the fuel flow of most common diesel engines, the typical sensor required allows for a maximum flow rate that is approximately 2.5 to 3 times the engine's maximum **fuel burn rate** (consumption rate). This information is commonly supplied by the engine manufacturer and known as 'wide open throttle', also known as 'WOT fuel consumption or burn rate'. This terminology of 'wide open throttle fuel consumption or burn rate' is not to be confused with maximum supply fuel flow rate.

#### **1.7.5.1 Calculating the Fuel System's Maximum Supply Fuel Flow Rate**

If you are unable to obtain the maximum supply fuel flow rates or the wide-open throttle fuel consumption or burn rate information from the engine manufacturer, there is another way to get a good estimate of the engine's supply fuel flow rate. For this alternative method to correctly select the proper fluid flow sensors, disconnect the fuel return line from the fuel tank and direct it into a fuel rated, five-gallon canister. Run the engine at maximum RPM until the fuel canister has reached its fuel capacity mark and calculate the return fuel flow rate by dividing the amount of fuel in the canister by the amount of time it took to fill the canister. For instance, if it took 15 minutes (0.25 hour) to fill the five-gallon canister, the return flow rate is:

$$\text{Max. return flow rate} = 5 \text{ gallons} / 0.25 \text{ hours} = 20 \text{ gallons per hour}$$

Now, add in the engine's consumption fuel rate at this RPM, which should be readily available from the manufacturer's documentation for the engine, and calculate the maximum supply flow rate as follows:

$$\text{Max. supply flow rate} = \text{Max. return flow rate} + \text{Max. consumption flow rate}$$

For this example, let's assume that the engine manufacturer's documentation shows that the fuel consumption of the engine at the maximum RPM is 5 gallons per hour. We can calculate the maximum supply flow rate as follows:

$$\text{Max. supply flow rate} = 20 \text{ gallons per hour} + 5 \text{ gallons per hour} = 25 \text{ gallons per hour.}$$

The 25 gallons per hour maximum supply flow rate is within the specifications of the M1AR fluid flow sensor, so the M1AR is appropriate for this fuel flow application.

If the maximum supply flow rate had exceeded the M1AR specifications, you would have needed to select the next larger fluid flow sensor, the M2AR.



## WARNING

For best results consult your engine's documentation or contact your engine manufacturer for the maximum supply fuel flow rate (sometimes called fuel feed rate) or the WOT fuel consumption or burn rate for the specific engine whose fuel consumption you wish to monitor.

### 1.7.6 Accuracy of Diesel Fuel Flow Measurement

Even though the fluid flow sensors used with the FFM100 are rated at  $\pm 0.25\%$  accuracy, since the fuel consumption measurement is calculated as the difference of the supply and return fuel flow rates, the accuracy of the fuel consumption measurement when operating in differential mode for a diesel engine depends on the ratio of the flow rate of fuel consumed by the engine to the flow rate of fuel supplied to the engine.

The following is a worst-case analysis of diesel engine fuel consumption measurement accuracy with a 4:1 supply rate to consumption rate ratio (this ratio is typical of many diesel engines). This assumes that both the supply and return fluid flow sensors are at the limit of their specifications in the way that will cause the most inaccuracy in the fuel consumption calculation.

Actual Supply Flow Rate:	80.0 LPH
Actual Fuel Consumption:	20.0 LPH
Actual Return Flow Rate:	60.0 LPH
Measured Supply Flow Rate	80.2 LPH ( <i>Assumes the supply sensor reads 0.25% high</i> )
Measured Return Flow Rate:	59.85 LPH ( <i>Assumes the return sensor reads 0.25% low</i> )
Calculated Fuel Consumption:	20.35 LPH
Error:	1.75 %

The resulting 1.75% error value is what appears in the FFM100 specifications for differential flow rate accuracy.

### 1.7.7 Choosing a Fluid Flow Sensor Mounting Location

Choosing a proper mounting location for fluid flow sensors is critical to obtaining accurate fluid flow measurements. Because of the positive displacement design of the FFM100 sensors, no pulse dampening is necessary. Any supply fluid flow sensor must be installed after a particle filter. There must not be any plumbing elbows or bends within 12 inches of the inlet or outlet of a fluid flow sensor. It is best that the sensor is located at the lowest point of the fluid flow system, ensuring that air cannot collect inside the sensor. Sensors must not be installed in a manner where the pipeline direction is oriented vertically but instead must be wall-mounted with the pipeline direction oriented horizontally. The installation instructions packaged with each fluid flow sensor contain additional details on choosing a mounting location and best installation practices. Please consult this instruction when plumbing and mounting the fluid flow sensors.

**NOTE: Maretron fluid flow sensors have anti-tamper blue silicone on one or more of the screws that hold the body of the sensor together. Do not remove these screws. Removing these screws will void the warranty on the sensor.**

## **2 Installation**

### **2.1 Unpacking the Box**

When unpacking the box containing the Maretron FFM100, you should find the following items:

- 1 – FFM100 Fuel Flow Monitor
- 1 – Parts Bag containing 4 qty Stainless Steel Mounting Screws
- 1 – FFM100 User's Manual
- 1 – Warranty Registration Card

If any of these items are missing or damaged, please contact Maretron.

### **2.2 Choosing a Mounting Location**

Please consider the following when choosing a mounting location.

1. The FFM100 is waterproof, so it can be mounted in a damp or dry location.
2. The orientation is not important, so the FFM100 can be mounted on a horizontal deck, vertical bulkhead, or upside down if desired.
3. The FFM100 is temperature-rated to 55°C (130°F), so it should be mounted away from engines or engine rooms where the operating temperature exceeds the specified limit.

### **2.3 Mounting the FFM100**

Attach the FFM100 securely to the vessel using the included stainless steel mounting screws or other fasteners as shown in Figure 6 below. Do not use threadlocking compounds containing methacrylate ester, such as Loctite Red (271), as they will cause stress cracking of the plastic enclosure.

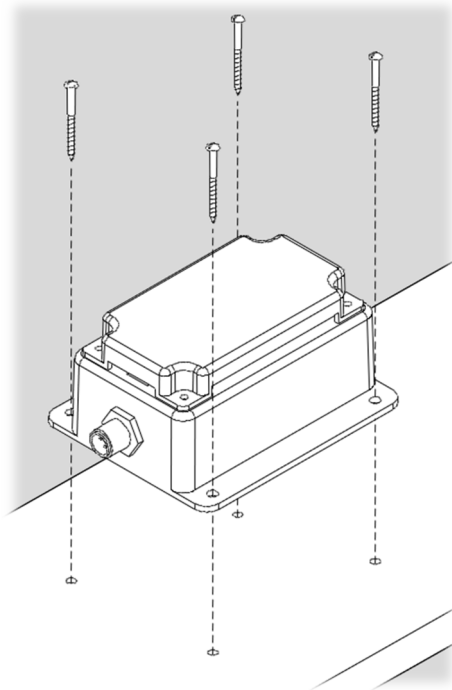
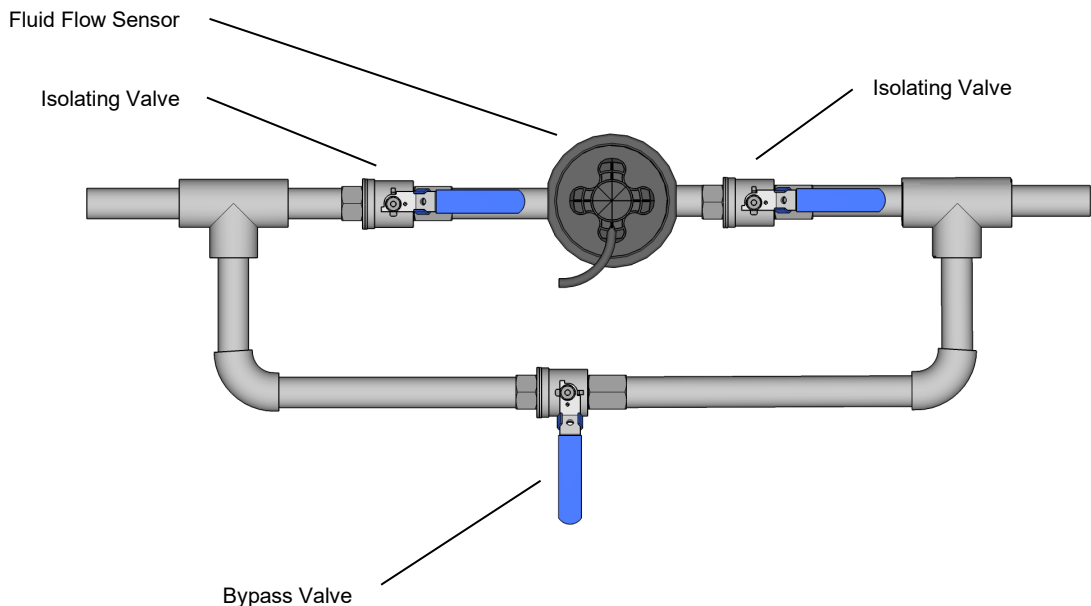

**Figure 6 – Mounting the FFM100**

## 2.4 Mounting & Connecting the Fluid Flow Sensor(s) to the vessel

1. The M1AR – M16AR fluid flow sensors contain shafts on which internal oval rotors spin. The fluid flow sensor must be mounted so that these rotor shafts are always in a horizontal plane (parallel with the ground or water surface).
2. Install so that the direction of the “FLOW” arrow on the sensor label matches the direction of fuel flow.
3. Use a liquid thread sealant on all pipe threads. Do NOT use Teflon tape. The fittings should be tightened hand tight, then a further 1/2 turn. Do not over tighten. Pipe strain or over tightening pipe connections can cause sensor damage or restrict fluid flow.
4. To prevent damage from foreign matter to M1AR – M16AR fluid flow sensors, it is recommended that a fluid filter capable of filtering out 75 micron particles is installed as close as possible to the inlet side of the supply fluid flow sensor – however, not oriented within 12 inches of said filter.
5. To prevent damage to the sensor from entrapped air during initial commissioning or after maintenance, fill the system with fuel to adequately lubricate the sensor(s). This can be achieved by priming the fluid plumbing. Failure to do this could damage the sensor. NEVER use compressed air through the sensor as this will damage the sensor.

When plumbing the fluid flow sensors into your fluid flow system, please keep in mind that the fluid flow sensors may need to be removed for servicing. Installing the fluid flow sensors with an isolating valve before and after the sensor (normally operated in the fully open position), and a bypass loop with a bypass valve (normally operated in the fully closed position) will enable the sensor to be removed for servicing while allowing fluid to flow normally through the system. Please refer to Figure 7 below for an example of bypass valve and isolating valve installation.



**Figure 7 – Fluid Flow Sensor Installation with Bypass and Isolating Valves**

The installation instructions packaged with each fluid flow sensor contain additional details on choosing a mounting location and best installation practices. Please consult this instruction when plumbing and mounting the fluid flow sensors

### 3 Connecting the Fluid Flow Sensor(s) to the FFM100

The FFM100 requires two types of electrical connections:

1. The fluid flow sensor connections, which are described in Section 3.1.1.
2. The NMEA 2000 connection (refer to Section 3.1.2).

#### 3.1.1 Fluid flow sensor Connections

The FFM100 fluid flow sensor connections are made by connecting to the 12-pin terminal strip on the top of the unit. First, remove the four screws at the corners of the unit detaching the splash guard from the unit. On the bottom of the splash guard, you will find a label detailing the wire connection to pin number assignments, which are repeated in the table below.

Pin #	Signal Name	Connection
1	P0	Fluid flow sensor 0 power connection
2	G0	Fluid flow sensor 0 ground connection
3	A0	Fluid flow sensor 0 phase A connection
4	B0	Fluid flow sensor 0 phase B connection
5	C0	Fluid flow sensor 0 phase C connection
6	T0	Fluid flow sensor 0 temperature sensor connection
7	P1	Fluid flow sensor 1 power connection
8	G1	Fluid flow sensor 1 ground connection
9	A1	Fluid flow sensor 1 phase A connection
10	B1	Fluid flow sensor 1 phase B connection
11	C1	Fluid flow sensor 1 phase C connection
12	T1	Fluid flow sensor 1 temperature sensor connection

**Table 1 - Fluid Flow Sensor Connections**

For differential mode, Channel 0 must be connected to the fluid flow sensor on the supply fuel line, and Channel 1 must be connected to the fluid flow sensor on the return fuel line.

Please refer to Figure 8 for connecting the FFM100 to an M1AR, M2AR, M4AR, M8AR, or M16AR fluid flow sensor. This figure shows the connection of the fluid flow sensor to channel 0. Connections with channel 1 are similar. When mounted in damp locations, the installation of dielectric grease on the terminal connections is recommended.

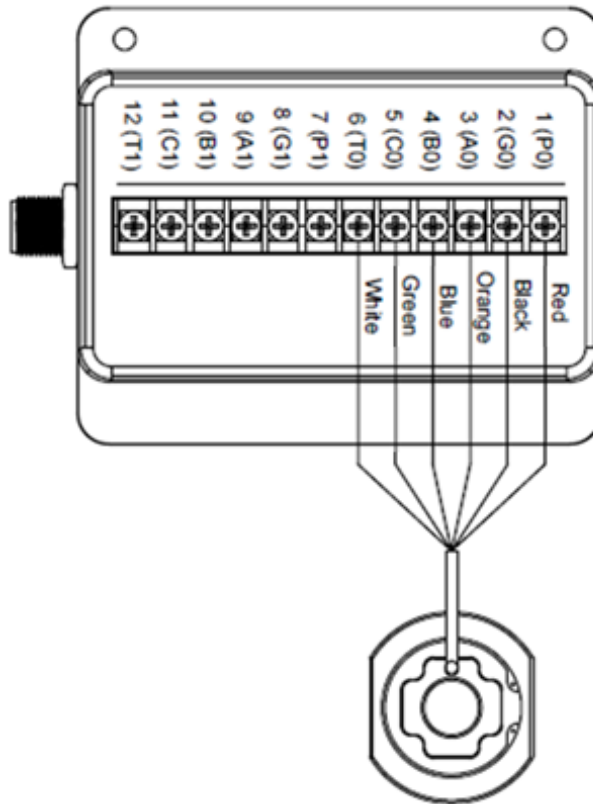

**Figure 8 – Fluid flow sensor Connection Diagram**

### 3.1.2 NMEA 2000 Connection

The NMEA 2000 connector can be found on the side of the FFM100 enclosure. The NMEA 2000 connector is a round five pin male connector (see Figure 9). You connect the FFM100 to an NMEA 2000 network using a Maretron NMEA 2000 cable (or an NMEA 2000 compatible cable) by connecting the female end of the cable to the FFM100 (note the key on the male connector and keyway on the female connector). Be sure the cable is connected securely and that the collar on the cable connector is tightened firmly. Connect the other end of the cable (male) to the NMEA 2000 network in the same manner. The FFM100 is designed such that you can plug or unplug it from an NMEA 2000 network while the power to the network is connected or disconnected. Please follow recommended practices for installing NMEA 2000 network products.

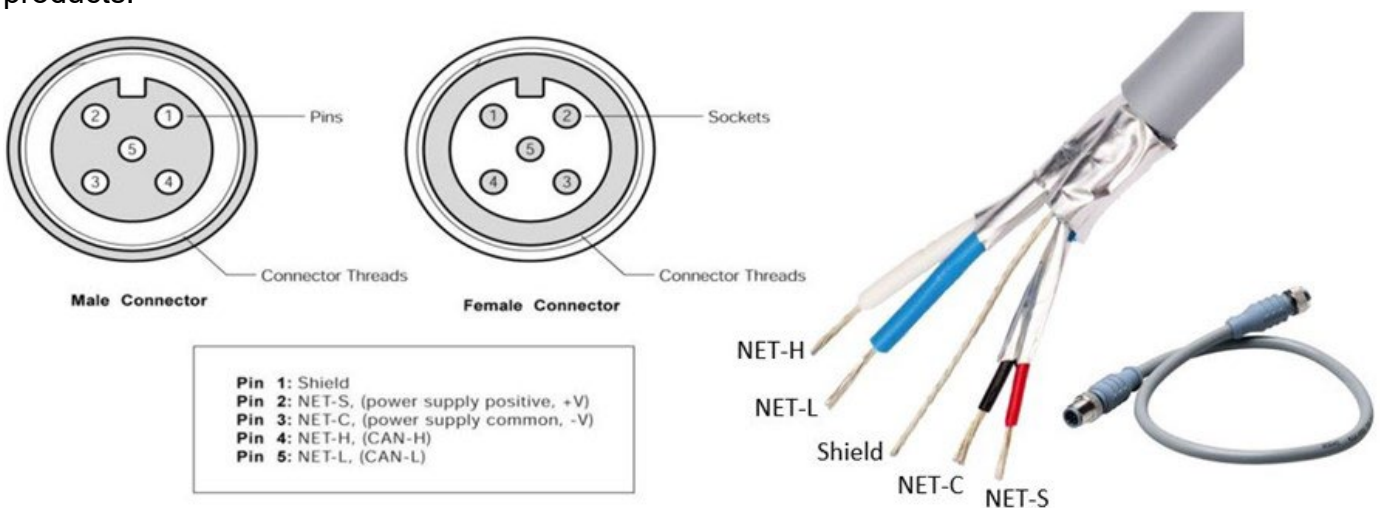

**Figure 9 – NMEA 2000® Connector**

## **4 Configuring the FFM100**

The FFM100 has several configurable parameters, which are shown below, including the default values. If you are not using the default values, then you will need to configure the FFM100 appropriately.

You can configure the FFM100 using a Maretron DSM-series display or Maretron N2KAnalyzer software. For full details on the configuration procedure, please refer to the User's Manual for the product which you are using to configure the FFM100.

1. Advanced Configuration (Section 4.1)
  - a. Device Instance
  - b. Channel-0 Installation
  - c. Channel-1 Installation
  - d. Channel-0 Allow negative flow
  - e. Channel-1 Allow negative flow
  - f. Differential Mode Allow negative flow
  - g. Installation Description
  - h. NMEA 2000 PGN Enable/Disable
  - i. Restore Factory Defaults
2. Device Label (Section 4.2)
3. Operating Mode (Section 4.3)
4. Channel #0 (Section 4.4)
  - a. Channel Enable/Disable (Section 4.4.1)
  - b. Engine Instance (Section 4.4.2)
  - c. Engine Label (Section 4.4.3)
  - d. K-Factor (Section 4.4.4)
  - e. Data Damping Period (Section 4.4.5)
  - f. Reset Total Volume Recorded (Section 4.4.6)
  - g. Temperature Instance (Section 4.4.7)
  - h. Temperature Source (Section 4.4.8)
  - i. Temperature Label (Section 4.4.9)
  - j. Flow Instance (Section 4.4.10)
  - k. Flow Label (Section 4.4.11)
  - l. Volume Instance (Section 4.4.12)
  - m. Volume Label (Section 4.4.13)
5. Channel #1 (Section 4.5)
  - a. Channel Enable/Disable (Section 4.5.1)
  - b. Engine Instance (Section 4.5.2)
  - c. Engine Label (Section 4.5.3)
  - d. K-Factor (Section 4.5.4)
  - e. Temperature Coefficient (Section 4.5.5)
  - f. Data Damping Period (Section 4.5.6)
  - g. Reset Total Volume Recorded (Section 4.5.7)
  - h. Temperature Instance (Section 4.5.8)
  - i. Temperature Source (Section 4.5.9)
  - j. Temperature Label (Section 4.5.10)
  - k. Flow Instance (Section 4.5.11)
  - l. Flow Label (Section 4.5.12)
  - m. Volume Instance (Section 4.5.13)
  - n. Volume Label (Section 4.5.14)

## 4.1 Advanced Configuration

### 4.1.1 Configuring Device Instance

NMEA 2000® provides a unique device instance for each flow measuring device on a vessel. This value should be programmed in each FFM100 so that each FFM100 is associated with a unique device instance number. The default instance number is 0, which is used to indicate the first FFM100 that is connected to the network. Subsequent FFM100s connected to the network would be numbered 1, 2, and so on.

### 4.1.2 Configuring Channel #0 Installation Orientation

If you install the Channel #0 fluid flow sensor with the “FLOW” arrow on the sensors pointing in the same direction as the fuel flow, you will not need to change this parameter from the factory default setting of “Normal”. If you inadvertently install the sensor in the reverse direction, rather than reinstalling the sensor, you may change this parameter from “Normal” to “Reverse”, and the FFM100 will compensate for the reversed installation of the flow sensor.

### 4.1.3 Configuring Channel #1 Installation Orientation

If you install the Channel #1 fluid flow sensor with the “FLOW” arrow on the sensors pointing in the same direction as the fuel flow, you will not need to change this parameter from the factory default setting of “Normal”. If you inadvertently install the sensor in the reverse direction, rather than reinstalling the sensor, you may change this parameter from “Normal” to “Reverse”, and the FFM100 will compensate for the reversed installation of the flow sensor.

### 4.1.4 Configuring Channel #0 Allow Negative Flow

The M1AR, M2AR, M4AR, M8AR, and M16AR fluid flow sensors are capable of sensing flow in both directions. When this parameter is in the default state of “Yes”, the FFM100 will report reverse flow on Channel #0 as a negative flow rate. If you do not wish to see negative flow rates from the Channel #0 sensor, you may change this parameter to “No”. When this parameter is set to “No”, the FFM100 will report a zero flow rate for Channel #0 when reverse flow occurs.

### 4.1.5 Configuring Channel #1 Allow Negative Flow

The M1AR, M2AR, M4AR, M8AR, and M16AR fluid flow sensors are capable of sensing flow in both directions. When this parameter is in the default state of “Yes”, the FFM100 will report reverse flow on Channel #1 as a negative flow rate. If you do not wish to see negative flow rates from the Channel #1 sensor, you may change this parameter to “No”. When this parameter is set to “No”, the FFM100 will report a zero flow rate for Channel #1 when reverse flow occurs.

### 4.1.6 Configuring Differential Mode Allow Negative Flow

In differential mode, if no fuel consumption is occurring, but fuel is flowing through both the supply and return fluid flow sensors, the resulting calculated net fuel consumption can result in a small negative value. When this parameter is set to the default state of “No”, the FFM100 will report this as a zero flow rate value. If you wish to see these small negative values transmitted by the FFM100, change the value of this parameter to “Yes”.

## **4.1.7 Configuring Installation Description**

You can configure the two installation description parameters with any text you wish. Examples include date of installation, location, etc. NMEA 2000 diagnostic tools such as Maretron N2KAnalyzer® can display this information.

## **4.1.8 Configuring NMEA 2000 PGN Enable/Disable**

The FFM100 is capable of transmitting NMEA 2000® messages (or PGNs) associated with monitored fluid senders. You may individually enable or disable each of these messages. You may also change the rate of transmission of each of these messages if desired.

## **4.1.9 Restoring Factory Default Settings**

Selecting this configuration option causes all stored parameters in the FFM100 to be reset to the values they contained when the unit was manufactured.

## **4.2 Configuring the Device Label**

Program this parameter with a text string which identifies this device. Maretron display products will display this label text when you are selecting data to display.

## **4.3 Configuring the Operating Mode**

The FFM100 can be operated in one of two selectable operating modes:

1. **Differential Flow Rate (default)** – in this mode, the FFM100 measures fuel consumption of a diesel engine by measuring the flow rate of the fuel sent from the fuel tank to the engine and the flow rate of the fuel returned from the engine to the fuel tank, and computing the difference between these two flow rates, with temperature compensation. This difference is the flow rate of the fuel actually consumed by the engine and is transmitted as a single parameter over the NMEA 2000 network. In this mode, Channel 0 must be connected to the fluid flow sensor on the supply fuel line, and Channel 1 must be connected to the fluid flow sensor on the return fuel line.
2. **Two Individual Flow Rates** – in this mode, the FFM100 can measure two independent flow rates of any fluids – diesel, oil, water, etc., and transmit the two flow rate measurements as separate parameters over the NMEA 2000 network.

## **4.4 Configuring Channel #0**

### **4.4.1 Enabling/Disabling Channel #0**

By default, the channel is enabled and will measure the flow rate and transmit it over the NMEA 2000 network. If this parameter is programmed to “Disable”, the channel will be completely disabled and will neither measure flow rate nor transmit it over the NMEA 2000 network.

### **4.4.2 Configuring Channel #0 Engine Instance**

Program this parameter to match the desired engine instance number of the flow rate and total fuel used for this channel. You can program this parameter to any value between 0 and 252. The default value for this parameter is 0.

## **4.4.3 Configuring Channel #0 Engine Label**

Program this parameter with a text string which identifies the particular parameter being monitored by this channel. Maretron display products will display this label text when you are selecting data to display.

## **4.4.4 Configuring Channel #0 K-factor**

Program this parameter to match the K-factor that appears on the flow sensor connected to this channel.

## **4.4.5 Configuring Channel #0 Data Damping Period**

You can configure a damping parameter to smooth the flow rate readings or make them more responsive. The data damping is configurable between 0.2-25.0 seconds. The default data damping period is 3.0 seconds.

## **4.4.6 Resetting the Total Volume Recorded for Channel #0**

The FFM100 maintains the total volume recorded in non-volatile memory so that it is maintained across power cycles. Select this menu entry to reset the total volume recorded to zero.

## **4.4.7 Configuring Channel #0 Temperature Instance**

Program this parameter to match the desired instance number of the temperature reading for this channel. You can program this parameter to any value between 0 and 252. The default value for this parameter is 0.

## **4.4.8 Configuring Channel #0 Temperature Source**

Program this parameter to match the desired instance number of the temperature reading for this channel. You can program this parameter to any value between 0 and 252. The default value for this parameter is 129 (User Defined).

## **4.4.9 Configuring Channel #0 Temperature Label**

Program this parameter with a text string which identifies the particular temperature parameter being monitored by this channel. Maretron display products will display this label text when you are selecting data to display.

## **4.4.10 Configuring Channel #0 Flow Instance**

Program this parameter to match the desired instance number of the flow reading for this channel. You can program this parameter to any value between 0 and 252. The default value for this parameter is 0.

## **4.4.11 Configuring Channel #0 Flow Label**

Program this parameter with a text string which identifies the particular flow parameter being monitored by this channel. Maretron display products will display this label text when you are selecting data to display.

### **4.4.12 Configuring Channel #0 Volume Instance**

Program this parameter to match the desired instance number of the volume reading for this channel. You can program this parameter to any value between 0 and 252. The default value for this parameter is 0.

### **4.4.13 Configuring Channel #0 Volume Label**

Program this parameter with a text string which identifies the particular volume parameter being monitored by this channel. Maretron display products will display this label text when you are selecting data to display.

## **4.5 Configuring Channel #1**

### **4.5.1 Enabling/Disabling Channel #1**

NOTE: This parameter is available only when the Operating Mode of the FFM100 is set to "Two Independent Flow Rates".

By default, the channel is enabled and will measure the flow rate and transmit it over the NMEA 2000 network. If this parameter is programmed to "Disable", the channel will be completely disabled and will not measure flow rate nor transmit it over the NMEA 2000 network.

### **4.5.2 Configuring Channel #1 Engine Instance**

NOTE: This parameter is available only when the Operating Mode of the FFM100 is set to "Two Independent Flow Rates".

Program this parameter to match the desired engine instance number of the flow rate and total fuel used for this channel. You can program this parameter to any value between 0 and 252. The default value of this parameter is 1.

### **4.5.3 Configuring Channel #1 Engine Label**

NOTE: This parameter is available only when the Operating Mode of the FFM100 is set to "Two Independent Flow Rates".

Program this parameter with a text string which identifies the particular parameter being monitored by this channel. Maretron display products will display this label text when you are selecting data to display.

### **4.5.4 Configuring Channel #1 K-factor**

Program this parameter to match the K-factor that appears on the flow sensor connected to this channel.

### **4.5.5 Configuring Channel #1 Temperature Coefficient**

NOTE: This parameter is available only when the Operating Mode of the FFM100 is set to "Differential Mode".

In a diesel engine, the diesel fuel is used to help cool the fuel injection system. Therefore, the fuel returned from the engine to the tank has a higher temperature than the fuel sent to the engine from the tank. Diesel fuel expands when heated. To calculate the most accurate fuel usage measurement, the FFM100 accounts for this expansion by sensing the temperature at

the supply flow sensor and the receive flow sensor and calculating the effect of the temperature difference on the fuel expansion. In order to perform this compensation, this parameter is programmed with the appropriate value for thermal expansion coefficient of the fluid being measured. The default value of this field is (0.083%/°C), which is appropriate for diesel fuel. The configuration tools have predefined values for common fluids: diesel, engine oil, gasoline, and water. You may select one of these values or choose your own.

## 4.5.6 Configuring Channel #1 Data Damping Period

NOTE: This parameter is available only when the Operating Mode of the FFM100 is set to "Two Independent Flow Rates".

You can configure a damping parameter to smooth the flow rate readings or make them more responsive. The data damping is configurable between 0.2-25.0 seconds. The default data damping period is 3.0 seconds.

## 4.5.7 Resetting the Total Volume Recorded for Channel #1

NOTE: This parameter is available only when the Operating Mode of the FFM100 is set to "Two Independent Flow Rates".

The FFM100 maintains the total volume recorded in non-volatile memory, so that it is maintained across power cycles. Select this menu entry to reset the total volume recorded to zero.

## 4.5.8 Configuring Channel #1 Temperature Instance

Program this parameter to match the desired instance number of the temperature reading for this channel. You can program this parameter to any value between 0 and 252. The default value for this parameter is 0.

## 4.5.9 Configuring Channel #1 Temperature Source

Program this parameter to match the desired instance number of the temperature reading for this channel. You can program this parameter to any value between 0 and 252. The default value for this parameter is 129 (User Defined).

## 4.5.10 Configuring Channel #1 Temperature Label

Program this parameter with a text string which identifies the particular temperature parameter being monitored by this channel. Maretron display products will display this label text when you are selecting data to display.

## 4.5.11 Configuring Channel #1 Flow Instance

NOTE: This parameter is available only when the Operating Mode of the FFM100 is set to "Two Independent Flow Rates".

Program this parameter to match the desired instance number of the flow reading for this channel. You can program this parameter to any value between 0 and 252. The default value for this parameter is 0.

## 4.5.12 Configuring Channel #1 Flow Label

NOTE: This parameter is available only when the Operating Mode of the FFM100 is set to "Two Independent Flow Rates".

Program this parameter with a text string which identifies the particular flow parameter being monitored by this channel. Maretron display products will display this label text when you are selecting data to display.

### **4.5.13 Configuring Channel #1 Volume Instance**

NOTE: This parameter is available only when the Operating Mode of the FFM100 is set to "Two Independent Flow Rates". Program this parameter to match the desired instance number of the volume reading for this channel. You can program this parameter to any value between 0 and 252. The default value for this parameter is 0.

### **4.5.14 Configuring Channel #1 Volume Label**

NOTE: This parameter is available only when the Operating Mode of the FFM100 is set to "Two Independent Flow Rates".

Program this parameter with a text string which identifies the particular volume parameter being monitored by this channel. Maretron display products will display this label text when you are selecting data to display.

## **5 Maintenance**

Regular maintenance is not required; however, an occasional inspection will ensure continued proper operation of the Maretron FFM100. Perform the following tasks periodically:

- Clean the unit with a soft cloth. Do not use chemical cleaners as they may remove paint or markings or may corrode the FFM100 enclosure or seals. Do not use any cleaners containing acetone, as they will deteriorate the plastic enclosure.
- Ensure that the unit is mounted securely and cannot be moved relative to the mounting surface. If the unit is loose, tighten the screws holding the cable ties.
- Check the security of the cable connected to the NMEA 2000® interface and tighten if necessary.
- Check the security of all of the fluid flow sensor connections on the top of the unit and tighten if necessary.

## 6 Troubleshooting

### 6.1 Troubleshooting Guide Table

If you notice unexpected operation of the Maretron FFM100, follow the troubleshooting procedures in this section to remedy simple problems.

Symptom	Troubleshooting Procedure
No Fuel Flow or Temperature data visible on NMEA 2000 network.	<ol style="list-style-type: none"> <li>1. Ensure that the FFM100 is properly connected to the NMEA 2000 network.</li> <li>2. Ensure that fluid flow sensors are properly connected to the FFM100.</li> <li>3. Ensure that each channel that you wish to monitor is configured correctly and that instance numbers are configured correctly.</li> <li>4. Ensure that the FFM100 has the appropriate NMEA 2000 PGNs enabled.</li> <li>5. Ensure that power is supplied to the NMEA 2000 network. Proper network power can be checked by measuring the voltage at an open tee between NET-S and NET-C. The voltage should be between 9 and 16 volts.</li> <li>6. Ensure that both trunk line terminators are in place. Proper network termination can be checked by removing network power and measuring the resistance at an open tee between NET-L and NET-H signals. The resistance should read approximately 60 ohms (two 120 ohm terminators in parallel equals 60 ohms).</li> </ol>
Fluid will not flow or reduced flow through the fluid flow sensors	<ol style="list-style-type: none"> <li>1. Check the meter for foreign matter blocking the rotors by pouring fluid through the sensor. If foreign matter is found to be blocking the rotors, please contact Maretron to obtain an RMA number in order to return the product to the factory for servicing.</li> <li>2. If a fuel / fluid line strainer / filter is installed, check to see whether it is blocked, and clean if necessary.</li> <li>3. Check the sensor fluid plumbing connections to see if they are over-tightened and re-adjust if necessary.</li> <li>4. Ensure that the fluid being measured is less than 1000 centipoise viscosity.</li> </ol>
Inaccurate fluid Flow reading	<ol style="list-style-type: none"> <li>1. Ensure that the fluid flow rate is within the minimum and maximum specifications for the sensor.</li> <li>2. Check for air in the system, and prime system plumbing.</li> <li>3. If a fuel / fluid line strainer / filter is installed, check to see if it is partially blocked, and clean if necessary.</li> <li>4. Ensure that the fluid being measured is less than 1000 centipoise viscosity.</li> </ol>

**Figure 10 – Troubleshooting Guide**

## **6.2 Troubleshooting Guide Supplement**

### **6.2.1 M1AR – M16AR Oval Gear Flow Sensor Operating Principle**

When fluid passes through the oval gear sensor, the oval gear's rotors turn (See figure below). Magnets located in the rotors will pass across sensors in the sensor circuit board. Pulses from these individual sensors are transmitted to the FFM100 which performs flow rate calculations based on the received pulses.

So long as the oval gears can turn, they will return an accurate signal respective to liquid flow for the FFM100's flow calculation.



### **6.2.2 M1AR - M16AR Oval Gear Troubleshooting**

Air collection in the oval gear sensor can stop the internal rotors from turning. In case of failure, the installer is encouraged not to assume that it is impossible for air to have collected in the oval gear sensor as a possible culprit for failure. Oftentimes when a sensor collects air, the reasoning can be attributed to insufficient fuel flow to push small air bubbles out of the sensor. If your engine fuel pump struggles to lift fuel, consider a booster pump to feed your system. Another possibility for air collection is sensor evacuation after the engine is shut down via siphon. If so, consider fitting a non-return valve or ensure flow sensors are fitted where they are always flooded. Please note that fuel flow can exist without the oval gear sensor rotors turning in the case a sensor has trapped air. If this occurs, it is possible for fuel-related engine troubles not to show because air trapped in an oval gear sensor does not prevent fuel flow but instead it can prevent rotors from turning.

Fouling of the oval gear sensor can also prevent oval gear rotors from rotating. If the oval gear sensor becomes fouled, additional fuel cleaning / filtering is required in the fuel system. If this happens or is suspected, please contact Maretron to obtain an RMA number in order to return the product to the factory for servicing.

### **6.2.3 FFM100 Differential System Troubleshooting**

Please note that in a differential system arrangement that when an engine is running and the fuel pump is pumping, the supply line will have a flow rate greater than the fuel burn, and the remainder fuel will return to the fuel tank. The difference between the supply fuel flow and the return fuel flow is fuel consumed by the engine. As you increase RPM, and load on the engine increases, the fuel consumption rate will increase and the return to the tank will decrease. Using this principle, troubleshooting can be performed in a differential system arrangement by temporarily setting the FFM100's operating mode as "Two Independent Flow Rates" using N2KAnalyzer and monitoring the system to ensure both sensors are recording flow to verify that both sensors are working. Furthermore, observation of the flow of the independent sensors with an understanding of the differential system general principles for a period of time will assist in understanding if one of the sensors are not working properly or wired incorrectly.

If it is deemed that one sensor is not working properly, please refer to “M1AR - M16AR Oval Gear Troubleshooting” above.

If there is no flow observed in N2KAnalyzer, then use a multi-meter set to Hz and measure across the three phase terminals (Orange, Blue, and Green) and observe a frequency from around 2Hz upwards. If there is a frequency observed, the rotors are turning but the FFM100 is not recognizing the sensor pulses. In this case, fluid flow sensor wire troubleshooting to the FFM100 module or FFM100 NMEA 2000 connection troubleshooting must be performed.

If there is no indication of flow in N2KAnalyzer and no frequency measured at the fluid flow sensor connection to the FFM100 module, then measure the voltage across both channel 1 and 2 between P0/G0 and between P1/G1. There should be 5V. If there is no 5V signal, the FFM100 may not be connected to the NMEA 2000 network or the NMEA 2000 network power supply is off. If the supply is on, the FFM100 module may be faulty.

## 7 Technical Specifications

### Specifications

Parameter	Value	Comment
Accuracy (Differential Mode)	±1.75% of reading	Using M1AR sensors K factors programmed into FFM100 4:1 fuel supply/fuel consumption ratio
Accuracy (Two Independent Sensors)	±0.25% of reading	Using M1AR sensor K factors programmed into FFM100
Resolution	0.1 LPH (0.026 GPH)	

### Certifications

Parameter	Comment
NMEA 2000®	Level A
Maritime Navigation and Radiocommunication Equipment & Systems	IEC 61162-3
Maritime Navigation and Radiocommunication Equipment & Systems	Tested to IEC 60945
FCC and CE Mark	Electromagnetic Compatibility

### NMEA 2000® Parameter Group Numbers (PGNs) - See Appendix A for Details

Description	PGN #	PGN Name	Default Rate
Periodic Data PGNs	065286	Fluid Flow Rate (Maretron Proprietary)	2 Times/Second
	065287	Trip Volume (Maretron Proprietary)	2 Times/Second
	127489	Engine Parameters, Dynamic	2 Times/Second
	127497	Trip Parameters, Engine	1 Time/Second
	130312	Temperature	0.5 Times/Second
	130316	Temperature, Extended Range	0.5 Times/Second
Response to Requested PGNs	126464	PGN List (Transmit and Receive)	N/A
	126996	Product Information	N/A
	126998	Configuration Information	N/A
Protocol PGNs	059392	ISO Acknowledge	N/A
	059904	ISO Request	N/A
	060928	ISO Address Claim	N/A
	065240	ISO Address Command	N/A
	126208	NMEA Request/Command/Acknowledge	N/A
	126993	Heartbeat	1 Time/Second
Maretron Proprietary PGNs	126720	Device Configuration Information	N/A
	130818	Device Label	N/A

## Electrical

Parameter	Value	Comment
Operating Voltage	9 to 32 Volts	DC Voltage
Power Consumption	150mA	Maximum Current Drain
Load Equivalence Number (LEN)	3	NMEA 2000® Spec. (1LEN = 50mA)
Reverse Battery Protection	Yes	Indefinitely
Load Dump Protection	Yes	Energy Rated per SAE J1113

## Mechanical

Parameter	Value	Comment
Size	3.50" x 4.20" x 2.03" (88.9mm x 106.7mm x 51.6mm)	Including Flanges for Mounting
Weight	13 oz. (368.5 g)	

## Environmental

Parameter	Value
IEC 60945 Classification	Exposed
Degree of Protection	IP64
Operating Temperature	-25°C to 55°C
Storage Temperature	-40°C to 70°C
Relative Humidity	93%RH @40° per IEC60945-8.2
Vibration	2-13.2Hz @ ±1mm, 13.2-100Hz @ 7m/s <sup>2</sup> per IEC 60945-8.7
Solar Radiation	Ultraviolet B, A, Visible, and Infrared per IEC 60945-8.10
Corrosion (Salt Mist)	4 times 7days @ 40°C, 95%RH after 2 hour Salt Spray Per IEC 60945-8.12
Electromagnetic Emission	Conducted and Radiated Emission per IEC 60945-9
Electromagnetic Immunity	Conducted, Radiated, Supply, and ESD per IEC 60945-10
Safety Precautions	Dangerous Voltage, Electromagnetic Radio Frequency per IEC 60945-12

## 8 Technical Support

If you require technical support for Maretron products, you can reach us in any of the following ways:

Toll Free: 1-866-550-9100  
Phone: 1-603-324-7900  
E-mail: [support@maretron.com](mailto:support@maretron.com)  
Customer Portal: [Customer.Raymarine.com](http://Customer.Raymarine.com)  
World Wide Web: <http://www.maretron.com>  
Mail: Raymarine-Maretron FL Service Center  
120 Intracoastal Pointe Drive  
Jupiter, FL 33477  
USA

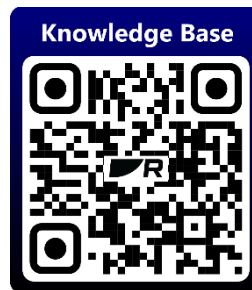

## 9 Installation Template

Please check the dimensions before using the following diagram as a template for drilling the mounting holes because the printing process may have distorted the dimensions.

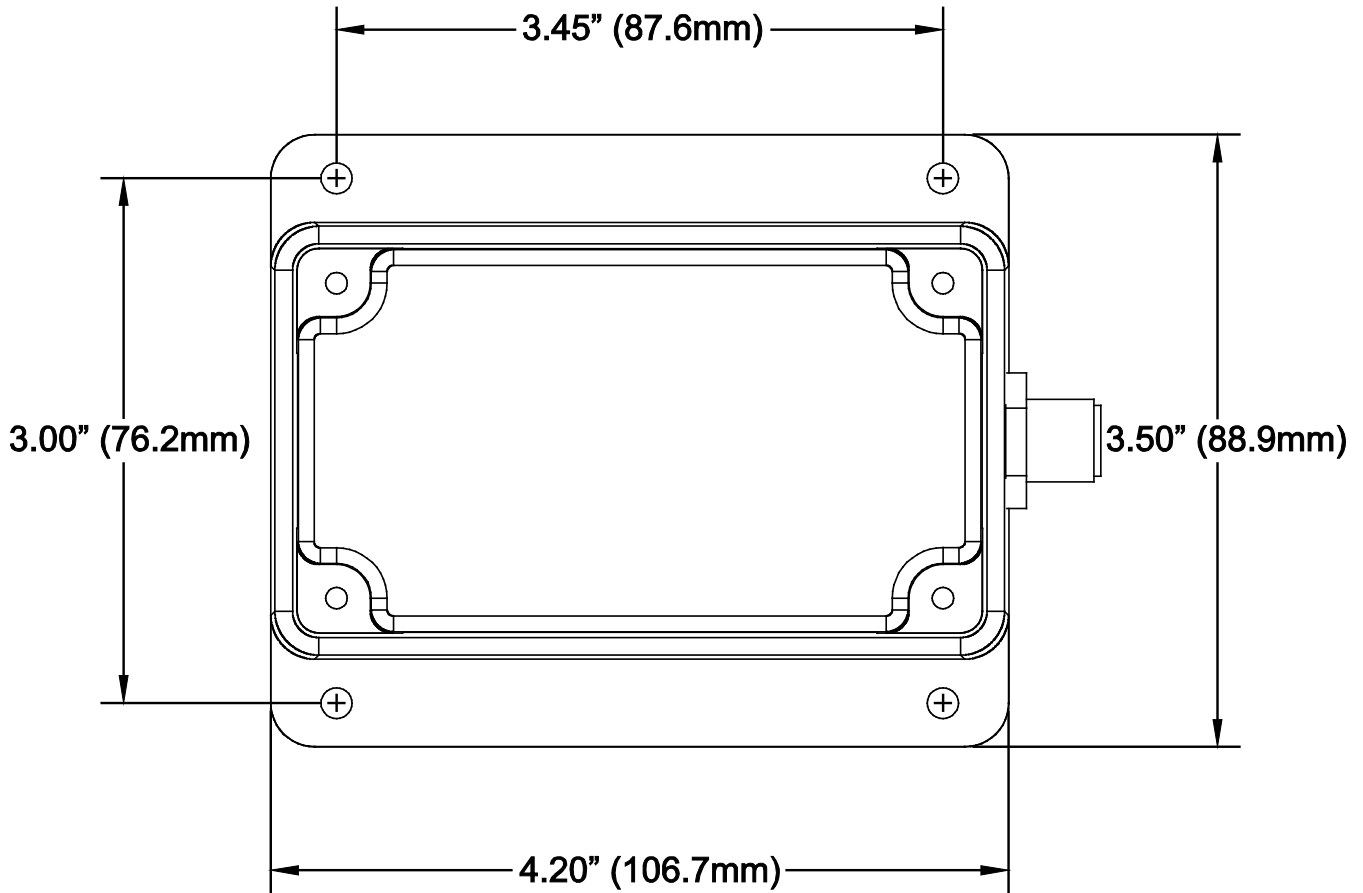

Figure 11 – Mounting Surface Template

## **10 Maretron (2 Year) Limited Warranty**

Maretron warrants the FFM100 to be free from defects in materials and workmanship for **two (2) years** from the date of original purchase. If within the applicable period any such products shall be proved to Maretron's satisfaction to fail to meet the above limited warranty, such products shall be repaired or replaced at Maretron's option. Purchaser's exclusive remedy and Maretron's sole obligation hereunder, provided product is returned pursuant to the return requirements below, shall be limited to the repair or replacement, at Maretron's option, of any product not meeting the above limited warranty and which is returned to Maretron; or if Maretron is unable to deliver a replacement that is free from defects in materials or workmanship, Purchaser's payment for such product will be refunded. Maretron assumes no liability whatsoever for expenses of removing any defective product or part or for installing the repaired product or part or a replacement therefore or for any loss or damage to equipment in connection with which Maretron's products or parts shall be used. With respect to products not manufactured by Maretron, Maretron's warranty obligation shall in all respects conform to and be limited to the warranty actually extended to Maretron by its supplier. The foregoing warranties shall not apply with respect to products subjected to negligence, misuse, misapplication, accident, damages by circumstances beyond Maretron's control, to improper installation, operation, maintenance, or storage, or to other than normal use or service.

THE FOREGOING WARRANTIES ARE EXPRESSLY IN LIEU OF AND EXCLUDES ALL OTHER EXPRESS OR IMPLIED WARRANTIES, INCLUDING BUT NOT LIMITED TO THE IMPLIED WARRANTIES OF MERCHANTABILITY AND OF FITNESS FOR A PARTICULAR PURPOSE.

Statements made by any person, including representatives of Maretron, which are inconsistent or in conflict with the terms of this Limited Warranty, shall not be binding upon Maretron unless reduced to writing and approved by an officer of Maretron.

IN NO CASE WILL MARETRON BE LIABLE FOR INCIDENTAL OR CONSEQUENTIAL DAMAGES, DAMAGES FOR LOSS OF USE, LOSS OF ANTICIPATED PROFITS OR SAVINGS, OR ANY OTHER LOSS INCURRED BECAUSE OF INTERRUPTION OF SERVICE. IN NO EVENT SHALL MARETRON'S AGGREGATE LIABILITY EXCEED THE PURCHASE PRICE OF THE PRODUCT(S) INVOLVED. MARETRON SHALL NOT BE SUBJECT TO ANY OTHER OBLIGATIONS OR LIABILITIES, WHETHER ARISING OUT OF BREACH OF CONTRACT OR WARRANTY, TORT (INCLUDING NEGLIGENCE), OR OTHER THEORIES OF LAW WITH RESPECT TO PRODUCTS SOLD OR SERVICES RENDERED BY MARETRON, OR ANY UNDERTAKINGS, ACTS OR OMISSIONS RELATING THERETO.

Maretron does not warrant that the functions contained in any software programs or products will meet purchaser's requirements or that the operation of the software programs or products will be uninterrupted or error free. Purchaser assumes responsibility for the selection of the software programs or products to achieve the intended results, and for the installation, use and results obtained from said programs or products. No specifications, samples, descriptions, or illustrations provided by Maretron to Purchaser, whether directly, in trade literature, brochures or other documentation shall be construed as warranties of any kind, and any failure to conform with such specifications, samples, descriptions, or illustrations shall not constitute any breach of Maretron's limited warranty.

### **Warranty Return Procedure:**

To apply for warranty claims, you must first contact Maretron or one of its dealers to describe the problem and determine the appropriate course of action. If a return is necessary, place the product in its original packaging together with proof of purchase and register your Maretron product via the Raymarine Customer Portal. Registration is required for all users. Within the Customer Portal locate Repair and Service option and Create new Request. User will be provided a shipping label for product to be sent to a select Raymarine-Maretron Service Location. \*Customer may incur charges for service and/or shipping if product is notably damaged by customer actions and not a behavior of manufacturing results. Maretron will return the replaced or repaired product with all shipping and handling prepaid except for requests requiring expedited shipping (i.e. overnight shipments). Failure to follow this warranty return procedure could result in the product's warranty becoming null and void.

**Customer Portal:**      [Customer.Raymarine.com](http://Customer.Raymarine.com)

Maretron reserves the right to modify or replace, at its sole discretion, without prior notification, the warranty listed above. To obtain a copy of the current warranty policy, please go to the following web page:

**Warranty Information:** <https://www.maretron.com/warranty/>

## Appendix A – NMEA 2000® Interfacing

### FFM100 NMEA 2000® Periodic Data Transmitted PGNs

#### **PGN 65286 – Fluid Flow Rate**

The FFM100 uses this proprietary PGN to provide a regular transmission of fluid flow rates for various types of fluids. The factory default for periodic transmission rate is twice every second. The transmission of this PGN can be disabled (see PGN 126208 – NMEA Request Group Function – Transmission Periodic Rate).

- Field 1: Manufacturer Code – This field contains Maretron's NMEA 2000® manufacturer code, which is 137.
- 2: Reserved – The FFM100 sets all bits in this field to a value of "1".
  - 3: Industry Group – This field contains the Marine industry group code, which is 4.
  - 4: SID – The sequence identifier field is used to tie related PGNs together.
  - 5: Flow Rate Instance – The FFM100 sets this field to identify a particular fluid flow measurement from the fluid type specified in Field 6. Every flow measurement from a given fluid type on the network should have a distinct instance value, so that monitoring devices and displays can identify which measurement is which.
  - 6: Fluid Type – This field is used to indicate the type of fluid flow measurement being taken. Possible values for this field include Fuel, Fresh Water, Waste Water, Live Well, Oil, and Black Water.
  - 7: Reserved bits – The FFM100 sets all bits in this field to a value of "1".
  - 8: Fluid Flow Rate – This field is used to indicate the rate of fluid flow in units of  $1 \times 10^{-4}$  m<sup>3</sup>/hour.

#### **PGN 65287 – Trip Volume**

The FFM100 uses this proprietary PGN to provide a regular transmission of trip volume. The factory default for periodic transmission rate is twice every second. The transmission of this PGN can be disabled and the trip volume can be reset over the NMEA 2000 network (see PGN 126208 – NMEA Request Group Function – Transmission Periodic Rate).

- Field 1: Manufacturer Code – This field contains Maretron's NMEA 2000® manufacturer code, which is 137.
- 2: Reserved – The FFM100 sets all bits in this field to a value of "1".
  - 3: Industry Group – This field contains the Marine industry group code, which is 4.
  - 4: SID – The sequence identifier field is used to tie related PGNs together.
  - 5: Volume Instance – The FFM100 sets this field to identify a particular trip volume measurement from the fluid type specified in Field 6. Every trip volume measurement from a given fluid type on the network should have a distinct instance value, so that monitoring devices and displays can identify which measurement is which.
  - 6: Fluid Type – This field is used to indicate the type of trip volume measurement being taken. Possible values for this field include Fuel, Fresh Water, Waste Water, Live Well, Oil, and Black Water.
  - 7: Reserved bits – The FFM100 sets all bits in this field to a value of "1".
  - 8: Trip Volume – This field is used to indicate the trip volume in units of  $1 \times 10^{-3}$  m<sup>3</sup>.

#### **PGN 127489 – Engine Parameters, Dynamic**

The FFM100 uses this PGN to transmit fluid flow rate information. The factory default for periodic transmission rate is twice per second. The transmission of this PGN can be disabled (see PGN 126208 – NMEA Request Group Function – Transmission Periodic Rate).

- Field 1: Engine Instance – This field indicates the particular engine for which this data applies. A single engine will have an instance of 0. Engines in multi-engine boats will be

- numbered starting at 0 at the bow of the boat incrementing to n going in towards the stern of the boat. For engines at the same distance from the bow are stern, the engines are numbered starting from the port side and proceeding towards the starboard side.
- 2: Engine Oil Pressure – The FFM100 sets this field to a reserved NMEA 2000 value indicating “Data Not Available”.
  - 3: Engine Oil Temperature – The FFM100 sets this field to a reserved NMEA 2000 value indicating “Data Not Available”.
  - 4: Engine Temperature – The FFM100 sets this field to a reserved NMEA 2000 value indicating “Data Not Available”.
  - 5: Alternator Potential – The FFM100 sets this field to a reserved NMEA 2000 value indicating “Data Not Available”.
  - 6: Fuel Rate – This field indicates the fuel consumption rate of the engine in units of 0.0001 cubic meters / hour.
  - 7: Total Engine Hours – The FFM100 sets this field to a reserved NMEA 2000 value indicating “Data Not Available”.
  - 8: Engine Coolant Pressure – The FFM100 sets this field to a reserved NMEA 2000 value indicating “Data Not Available”.
  - 9: Fuel Pressure – The FFM100 sets this field to a reserved NMEA 2000 value indicating “Data Not Available”.
  - 10: Reserved – The FFM100 sets all bits in this field to a value of “1”.
  - 11: Engine Discrete Status 1 – The FFM100 sets all bits in this field to a value of “0”.
  - 12: Engine Discrete Status 2 – The FFM100 sets all bits in this field to a value of “0”.
  - 13: Percent Engine Load – The FFM100 sets this field to a reserved NMEA 2000 value indicating “Data Not Available”.
  - 14: Percent Engine Torque – The FFM100 sets this field to a reserved NMEA 2000 value indicating “Data Not Available”.

### **PGN 127497 – Trip Parameters, Engine**

The FFM100 uses this PGN to transmit more slowly changing engine data. The factory default for periodic transmission rate is once per second. The transmission of this PGN can be disabled (see PGN 126208 – NMEA Request Group Function – Transmission Periodic Rate).

- Field 1: Engine Instance – This field indicates the particular engine for which this data applies. A single engine will have an instance of 0. Engines in multi-engine boats will be numbered starting at 0 at the bow of the boat incrementing to n going in towards the stern of the boat. For engines at the same distance from the bow are stern, the engines are numbered starting from the port side and proceeding towards the starboard side.
- Field 2: Trip Fuel Used – This field indicates the total fuel used since the counter was last reset with a resolution of 0.001 cubic meters.
- Field 3: Fuel Rate, Average – The FFM100 sets this field to a reserved NMEA 2000 value indicating “Data Not Available”.
- Field 4: Fuel Rate, Economy – This field indicates the current fuel consumption rate with a resolution of 0.0001 cubic meters / hour.
- Field 5: Instantaneous Fuel Economy – This field indicates the current fuel consumption rate with a resolution of 0.0001 cubic meters / hour.

### **PGN 130312 – Temperature**

The FFM100 uses this PGN to provide a regular transmission of fluid temperatures. The factory default for periodic transmission rate is once every two seconds. The transmission of this PGN can be disabled (see PGN 126208 – NMEA Request Group Function – Transmission Periodic Rate).

- Field 1: SID – The sequence identifier field is used to tie related PGNs together.

- 2: Temperature Instance – The FFM100 sets this field to identify a particular temperature measurement from the source specified in Field 3. Every temperature measurement from a given source type on the network should have a distinct instance value, so that monitoring devices and displays can identify which measurement is which.
- 3: Temperature Source – This field is used to indicate the type of temperature measurement being taken. Possible values for this field include Sea Temperature, Outside Temperature, Inside Temperature, Engine Room Temperature, Main Cabin Temperature, Live Well Temperature, Bait Well Temperature, Refrigeration Temperature, Heating System Temperature, and Freezer Temperature.
- 4: Actual Temperature – This field is used to indicate the temperature, whose source is specified in field 2, in units of 0.01°C.
- 5: Set Temperature – The FFM100 sets this field to a reserved NMEA 2000 value indicating “Data Not Available”.
- 6: Reserved bits – The FFM100 sets all bits in this field to a value of “1”.

## **PGN 130316 –Temperature, Extended Range**

The FFM100 uses this PGN to provide a regular transmission of fluid temperatures. The factory default for periodic transmission rate is once every two seconds. The transmission of this PGN can be disabled (see PGN 126208 – NMEA Request Group Function – Transmission Periodic Rate).

- Field 1: SID – The sequence identifier field is used to tie related PGNs together.
- 2: Temperature Instance – The FFM100 sets this field to identify a particular temperature measurement from the source specified in Field 3. Every temperature measurement from a given source type on the network should have a distinct instance value, so that monitoring devices and displays can identify which measurement is which.
  - 3: Temperature Source – This field is used to indicate the type of temperature measurement being taken. Possible values for this field include Sea Temperature, Outside Temperature, Inside Temperature, Engine Room Temperature, Main Cabin Temperature, Live Well Temperature, Bait Well Temperature, Refrigeration Temperature, Heating System Temperature, and Freezer Temperature.
  - 4: Actual Temperature – This field is used to indicate the temperature in units of 0.001°C.
  - 5: Set Temperature – The FFM100 sets this field to a reserved NMEA 2000 value indicating “Data Not Available”.
  - 6: Reserved bits – The FFM100 sets all bits in this field to a value of “1”.