

# SSC200 Solid State Rate/Gyro Compass

## User's Manual

Revision 1.7

Copyright © 2006 Maretron, LLC All Rights Reserved

Maretron, LLC  
9034 N. 23<sup>rd</sup> Ave #13  
Phoenix, AZ 85021-7850  
<http://www.maretron.com>

Maretron Manual Part #: M000401

## Revision History

Revision	Description
1.0	Original document.
1.1	Minor editorial changes. Corrected default rate for Rate of Turn PGN under Technical Specifications.
1.2	Minor editorial changes. Removed Warranty Card.
1.3	Changed copyright to 2005.
	Added text to describe new feature (programmable variation) under Section 1.2, 3.0, 3.3, and Appendix B.
1.4	Added Variation section. Added Rate of Turn section. Updated Appendix A Maretron Proprietary Execute Sentence definitions. Updated Appendix A Maretron Proprietary Set Period sentence table. Added programming examples to Appendix A Maretron Proprietary Set Period for enabling, disabling, and changing frequency of transmission of different NMEA 0183 sentences. Added Calibration Warning
1.5	Added Firmware Revision section indicating firmware revision 1.9 Added note to Appendix A that checksums are optional and removed checksums from received sentences. Added deviation compass environment quality measurements report from compass. Added rate of turn zeroing section.
1.6	Updated Supported Firmware Revision to 2.0. Incorporated instructions on interfacing directly to a PC as Appendix C Incorporated Magnetic Variation App Note (AN2) as Appendix D Incorporated HDT App Note (AN1) as Appendix E Added support for 38400 baud rate for P/N M000021 compasses.
1.7	Updated Section 3.1.2 describing compass output after successful deviation. Updated installation to include power connections through NMEA 2000 port Updated installation – SSC200 can be installed upside down and/or backward

## Table of Contents

1	General .....	1
1.1	Introduction.....	1
1.2	Firmware Revision.....	1
1.3	Features .....	1
1.4	Quick Install.....	1
2	Installation.....	2
2.1	Unpacking the Box .....	2
2.2	Choosing a Mounting Location .....	2
2.3	Mounting the SSC200 .....	3
2.3.1	Mounting the SSC200 to a Horizontal Surface .....	3
2.3.2	Mounting the SSC200 to a Vertical Surface .....	4
2.4	Connecting the SSC200.....	5
2.4.1	Connecting to NMEA 2000® Interface .....	6
2.4.2	Connecting to NMEA 0183 Interface .....	7
	If the NMEA 2000® interface is connected, power is supplied to the SSC200 through the NMEA 2000® network connection.....	8
2.4.3	Connecting Both NMEA 2000® and NMEA 0183 Interfaces.....	10
2.4.4	Checking Connections.....	10
3	Calibration.....	10
3.1	Magnetic Deviation Calibration.....	10
3.1.1	Maretron Display Initiated Deviation Calibration.....	11
3.1.2	Automatic Power-Up Deviation Calibration.....	11
3.2	Installation-Offset Correction .....	12
3.2.1	Maretron Display Product Offset Correction .....	12
3.2.2	Manual Installation-Offset Correction .....	12
4	Variation.....	13
4.1	Variation Input via NMEA 0183 Interface.....	13
4.2	Variation Input via the NMEA 2000® Interface.....	14
4.3	Variation Input via Manual Entry.....	14
4.4	Variation Source Selection .....	15
4.4.1	Variation Source Selection via Maretron Display.....	15
4.4.2	Variation Source Selection via NMEA 0183 Interface.....	15
5	Rate of Turn .....	15
5.1	Rate of Turn Damping Period Selection with Maretron Display.....	16
5.2	Rate of Turn Damping Period Selection by NMEA 0183 Interface .....	16
5.3	Rate of Turn Zeroing .....	16
6	Maintenance .....	16
7	Troubleshooting .....	17
8	Technical Specifications.....	18
9	Technical Support.....	19
10	Installation Template .....	20
11	Maretron (2 Year) Limited Warranty.....	21

## **Table of Figures**

Figure 1 – Mounting the SSC200 to a Horizontal Surface .....	4
Figure 2 – Mounting the SSC200 to Vertical Surface .....	5
Figure 3 – NMEA 2000® / NMEA 0183 Interface Connector Locations .....	6
Figure 4 – NMEA 2000®/Power Connector Face Views .....	6
Figure 5 - SSC200 with NMEA 2000® Connection Only .....	7
Figure 6 – NMEA 0183 Connector Face Views .....	8
Figure 7 – NMEA 0183 Cable/Wire Color Coding.....	8
Figure 8 - SSC200 with NMEA 0183 Connection Only .....	9
Figure 9 – Trouble Shooting Guide.....	17
Figure 10 – Horizontal Mounting Surface Template .....	20
Figure 11 – Vertical Mounting Surface Template.....	20

## **Table of Appendices**

Appendix A – NMEA 0183 Interfacing .....	A1
Appendix B – NMEA 2000® Interfacing.....	B1
Appendix C – Connecting to a PC Via NMEA 0183.....	C1
Appendix D – Configuring the SSC200 to Transmit True Heading Data .....	D1
Appendix E – Configuring the SSC200 to Transmit the HDT Sentence for ...and Radars .....	E1

## 1 General

### 1.1 Introduction

Congratulations on your purchase of the Maretron SSC200 Solid State Rate/Gyro Compass. Maretron has designed and built your compass to the highest standards for years of reliable, dependable, and accurate service.

The SSC200 detects the direction of the earth's magnetic field using solid state magnetometers and indicates the vessel heading relative to magnetic north. In addition, the SSC200 incorporates solid state accelerometers and a solid state angular rate sensor for indicating the vessel's attitude (pitch and roll) and rate of turn.

The Maretron SSC200 is designed to operate within the harsh demands of the marine environment. However, no piece of marine electronic equipment can function properly unless installed, calibrated, and maintained in the correct manner. Please read carefully and follow these instructions for installation, calibration, and usage of the Maretron SSC200 in order to ensure optimal performance.

### 1.2 Firmware Revision

This manual corresponds to SSC200 firmware revision 2.0.

### 1.3 Features

The Maretron SSC200 Solid State Compass has the following features.

- NMEA 2000® and NMEA 0183 Interfaces
- Solid State Magnetometers for Indicating the Vessel's Heading
- Solid State Accelerometers for Indicating the Vessel's Attitude (Pitch and Roll)
- Solid State Angular Rate Sensor for Indicating the Vessel's Rate of Turn
- Advanced Kalman Filtering for Stable and Accurate Output During Dynamic Conditions
- Fast Response Time Stabilizes Auto-Pilot Systems
- Calibration for Compensating Magnetic Deviation Caused by Hard and Soft Iron Effects
- Installation-Offset Capability for Aligning the Compass to the Vessel
- Programmable Variation
- Waterproof Enclosure and Cable System

### 1.4 Quick Install

Installing the Maretron SSC200 compass involves the following six steps. Please refer to the individual sections for additional details.

1. Unpack the Box (Section 2.1)
2. Choose a Mounting Location (Section 2.2)
3. Mount the SSC200 Compass (Section 2.3)
4. Connect the SSC200 Compass (Section 2.4)
5. Calibrate the SSC200 Compass for Magnetic Deviation (Section 3.1)

6. Calibrate the SSC200 Compass for Installation-Offset (Section 3.2)
7. Use Default Variation Source or Select an Appropriate Variation Source (Section 4)

## **2 Installation**

### **2.1 Unpacking the Box**

When unpacking the box containing the Maretron SSC200, you should find the following items.

- 1 - SSC200 Solid State Compass
- 2 - Mounting Brackets
- 4 - Mounting Bracket Screws
- 4 - Mounting Screws
- 1 - 10 meter NMEA 0183 Cable
- 1 - NMEA 2000<sup>®</sup> Micro Field Attachable Connector (Female)
- 1 - SSC200 User's Manual
- 1 - Warranty Registration Card

If any of these items are missing or damaged, please contact Maretron.

### **2.2 Choosing a Mounting Location**

The selection of a suitable mounting location is important for the optimal performance of the Maretron SSC200. The mounting location and orientation of the Maretron SSC200 should be:

1. *Level with the Earth's Horizontal Plane* – Although the SSC200 can be calibrated in the vessel to compensate for pitch and roll installation-offset, it is best to mount the compass as level as possible to maximize its pitch and roll operational range.
2. *Oriented with Arrow Pointing to Bow Parallel to Vessel Centerline* – Although the SSC200 can be calibrated in the vessel to compensate for heading installation-offset, it is best to mount the compass pointed towards the bow and parallel to the vessel centerline. The SSC200 can be mounted in other orientations, although this requires additional configuration steps; please refer to Section 2.3 on page 3 for details.
3. *Near the Center of Gravity (CG) of the Vessel* – The compass experiences the least amount of movement when located at the CG, which allows the most accurate readings. This is similar to a traditional card/needle compass, where the farther the compass is from the CG, then the more the fluid sloshes around, making accurate readings more difficult.
4. *Away from Structures Containing Ferrous Metals* – The earth's lines of magnetic flux tend to become distorted in the vicinity of ferrous metals, which can potentially cause errors in the compass's indicated heading. The SSC200 can be calibrated to compensate for these errors, but it is still best to minimize the errors by placing the compass as far away from ferrous metals as is practical.
5. *Away from Magnetic Field Sources* – Power or ignition cables, electric motors, and other electronic equipment can create magnetic fields. The earth's lines of magnetic flux tend to become distorted in the vicinity of magnetic field sources, which can potentially cause errors in the compass's indicated heading. The magnetic fields tend to come and go as power is switched on and off, which makes compensation impractical. Therefore, you should try to mount the compass as far away as possible from these magnetic field sources (doubling the

distance between the magnetic field source and the compass will reduce the field strength by a factor of approximately 8). Also, always observe any “compass-safe distance” markings on other electronic equipment.

6. *Minimal Vibration* – Although the SSC200 is more tolerant of vibration than a fluxgate compass, it is best to mount the compass in a location free of vibration as opposed to a location with vibration.

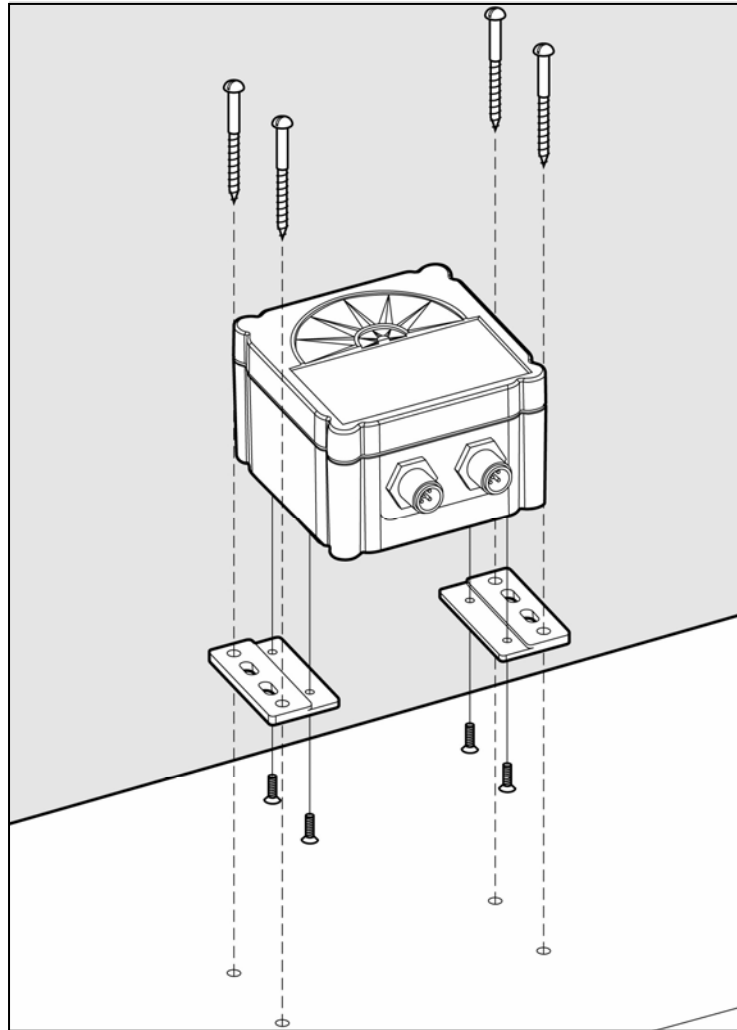
## **2.3 Mounting the SSC200**

The Maretron SSC200 compass can be mounted to a horizontal surface such as a floor or deck (Section 2.3.1) or it can be mounted to a vertical surface such as a wall or bulkhead (Section 2.3.2).

### **2.3.1 Mounting the SSC200 to a Horizontal Surface**

Mounting the SSC200 compass to a horizontal surface requires that the provided mounting brackets be fastened to the bottom of the SSC200 using the provided brass flat head screws. Once the mounting brackets are securely fastened to the bottom of the SSC200, attach the SSC200 securely to the vessel using the included brass mounting screws or other non-ferrous fasteners as shown in Figure 1.

The usual way of mounting the SSC200 to a horizontal surface is to mount it to the top of the horizontal surface; however, the SSC200 may be mounted upside down to the underside of a horizontal surface, provided that the SSC200 is programmed to recognize that it is mounted upside down. This can be done using a Maretron display product (e.g., DSM200 - please refer to the DSM200 user's manual for details).



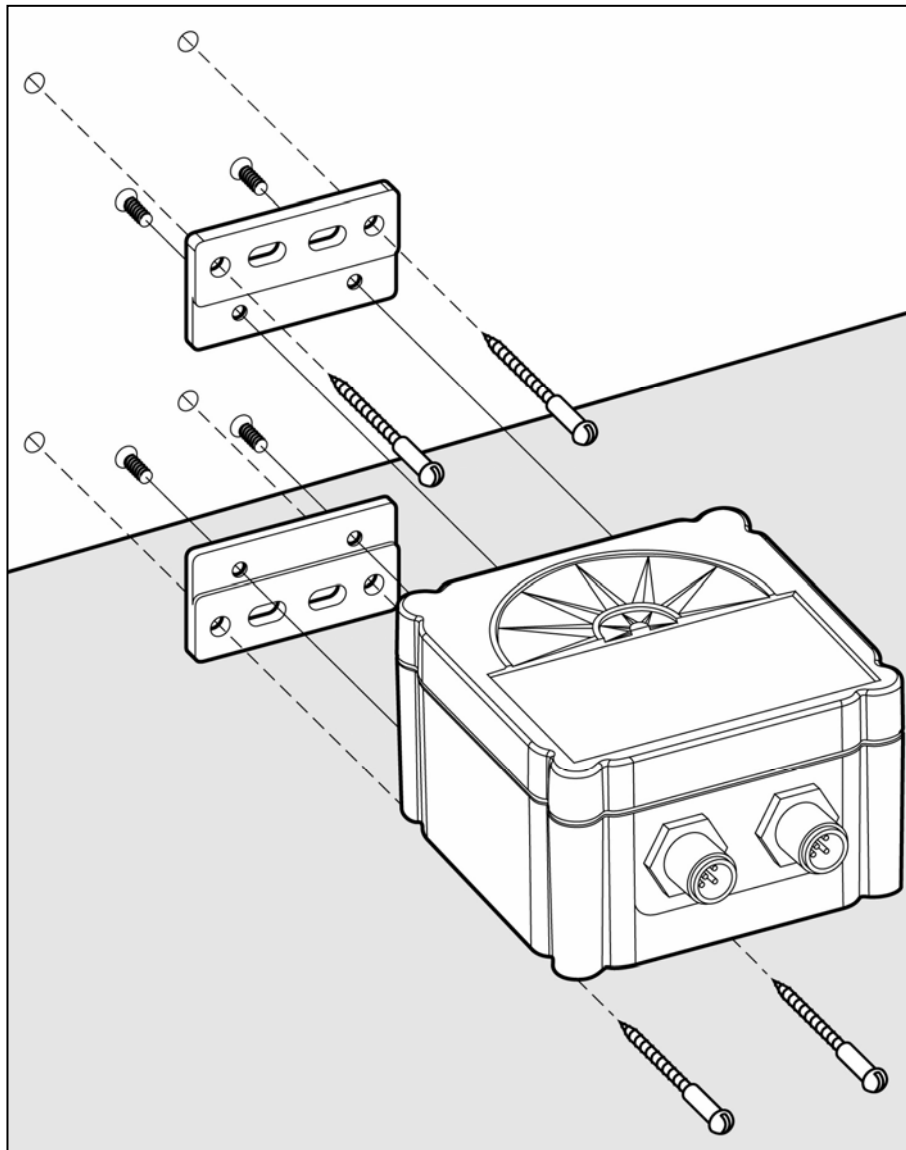
**Figure 1 – Mounting the SSC200 to a Horizontal Surface**

### **2.3.2 Mounting the SSC200 to a Vertical Surface**

Mounting the SSC200 compass to a vertical surface requires that the provided mounting brackets be fastened to the side of the SSC200 using the provided brass flat head screws. Once the mounting brackets are securely fastened to the side of the SSC200, attach the SSC200 securely to the vessel using the included brass mounting screws or other non-ferrous fasteners as shown in Figure 2.

The usual way of mounting the SSC200 to a vertical surface is attaching the SSC200 to the forward side of a vertical surface, so that the side of the compass with the connectors is facing the bow of the boat; however, the SSC200 may be mounted to the astern side of a vertical surface, so that the side of the compass with the connectors is facing the stern of the boat, provided that the SSC200 is programmed to recognized that it is mounted in this way (“backwards”). This can be done using a Maretron display product (e.g., DSM200 - please refer to the DSM200 user’s manual for details).

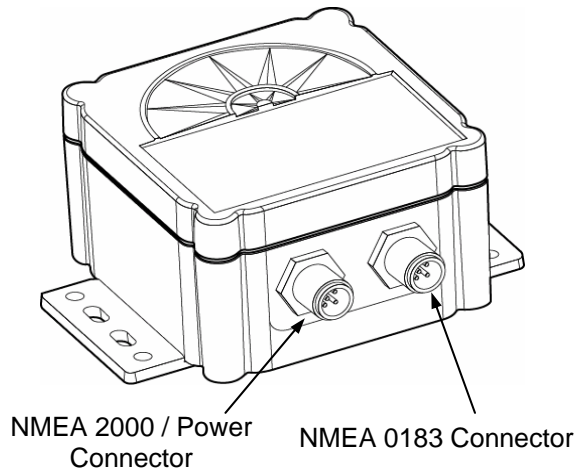




**Figure 2 – Mounting the SSC200 to Vertical Surface**

## 2.4 Connecting the SSC200

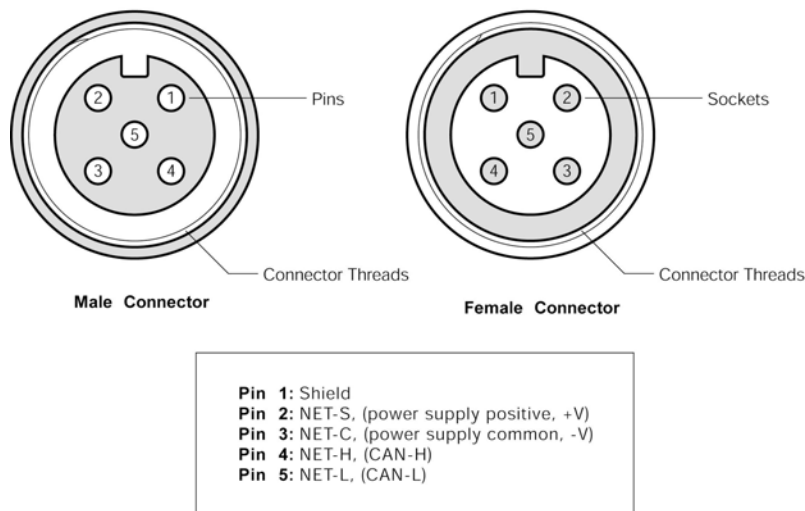
You have a choice of connecting the SSC200 to a NMEA 2000® interface (Section 2.4.1), NMEA 0183 interface (Section 2.4.2), or connecting both interfaces simultaneously (Section 2.4.2.2).



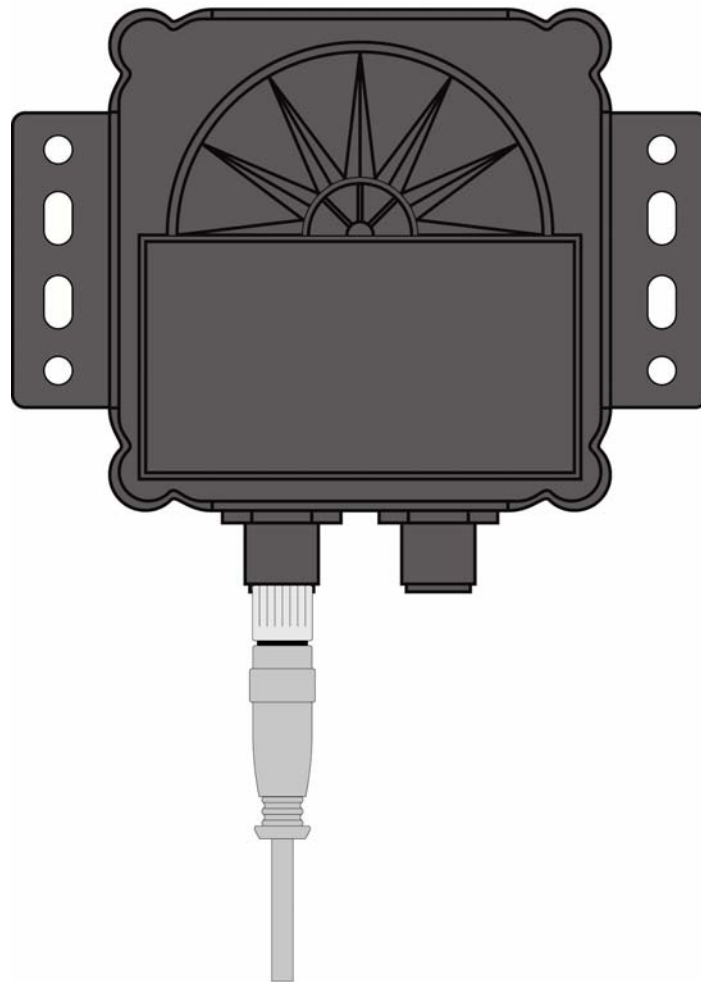
**Figure 3 – NMEA 2000<sup>®</sup> / NMEA 0183 Interface Connector Locations**

## 2.4.1 Connecting to NMEA 2000<sup>®</sup> Interface

The Maretron SSC200 provides a connection to an NMEA 2000<sup>®</sup> interface through a five pin male connector (Figure 4). You connect the SSC200 to an NMEA 2000<sup>®</sup> network using a Maretron NMEA 2000<sup>®</sup> cable (or compatible cable) by connecting the female end of the cable to the SSC200 (note the key on the male connector and keyway on the female connector) as shown in Figure 5 below.. Be sure the cable is connected securely and that the collar on the cable connector is tightened firmly. Connect the other end of the cable (male) to the NMEA 2000<sup>®</sup> network in the same manner. The SSC200 is designed such that you can plug or unplug it from an NMEA 2000<sup>®</sup> network while the power to the network is connected or disconnected. Please follow recommended practices for installing NMEA 2000<sup>®</sup> network products.



**Figure 4 – NMEA 2000<sup>®</sup>/Power Connector Face Views**

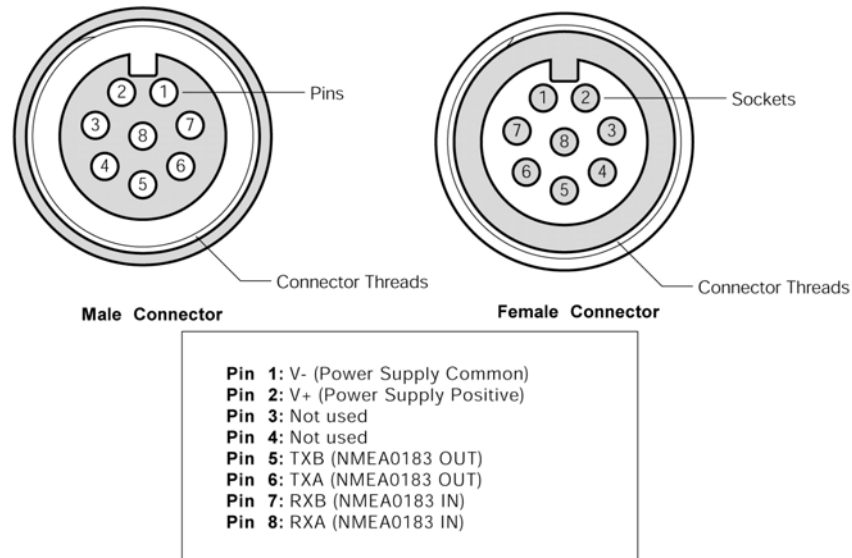


NMEA2000/Power Connection

**Figure 5 - SSC200 with NMEA 2000® Connection Only**

## 2.4.2 Connecting to NMEA 0183 Interface

The Maretron SSC200 provides a connection to an NMEA 0183 interface through an eight pin male connector (Figure 6). You connect the SSC200 to an NMEA 0183 network using the Maretron supplied cable by connecting the female end of the cable to the SSC200 (note the key on the male connector and keyway on the female connector). Be sure the cable is connected securely and that the collar on the cable connector is tightened firmly.



**Figure 6 – NMEA 0183 Connector Face Views**

Connect the other end of the cable consisting of individual wires using recommended practices for installing NMEA 0183 products. The individual wires found within the cable have the following color coding.

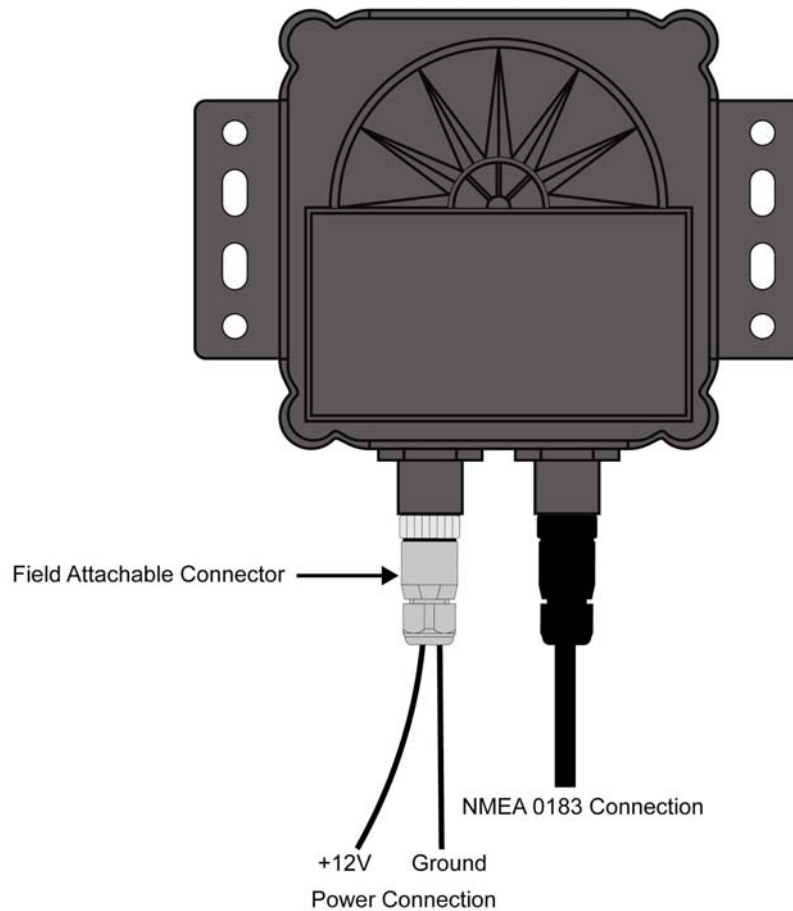
Wire Color	Name	Description
Gray	TXA	Transmit Differential Output A Signal
Brown	TXB	Transmit Differential Output B Signal
Blue	RXA	Receive Differential Input A Signal
White	RXB	Receive Differential Input B Signal

**Figure 7 – NMEA 0183 Cable/Wire Color Coding**

### 2.4.2.1 Power Connections

If the NMEA 2000<sup>®</sup> interface is connected, power is supplied to the SSC200 through the NMEA 2000<sup>®</sup> network connection.

If only the NMEA 0183 interface is used, power connections must be made via the NMEA 2000<sup>®</sup>/Power connector. Using the included Micro Field Attachable Connector (Female), connect two power wires (not included) to pins 2 and 3 of the field attachable connector (only the two power pins need be connected) as shown in Figure 4 on page 6, assemble the connector per the instructions packaged with the connector, and screw the connector snugly into the NMEA 2000<sup>®</sup>/Power connector on the SSC200, as shown in Figure 8 below.



**Figure 8 - SSC200 with NMEA 0183 Connection Only**

### 2.4.2.2 Supported NMEA 0183 Baud Rates

The SSC200 compass supports NMEA0183 communication at both 4800 baud and 38400 baud. All SSC200 Compasses are shipped with a baud rate of 4800 baud. The baud rate may be set to 38400 baud by connecting to the compass using a terminal emulator (See Appendix C for details) and sending the following strings to the compass through the NMEA 0183 connection:

```
shell
```

This will cause the “cmd>” command prompt to be displayed

```
tm setbaud 38400
```

At this point, you must change the baud rate of your connection to 38400 baud to continue, as the SSC200 has now been set to the higher baud rate.

```
tm storebaud
```

This causes the new baud rate to be stored to non-volatile memory, so the compass will retain this baud rate when it is powered down.

### **2.4.3 Connecting Both NMEA 2000<sup>®</sup> and NMEA 0183 Interfaces**

The SSC200 can be simultaneously connected to both an NMEA 2000<sup>®</sup> network and an NMEA 0183 network.

### **2.4.4 Checking Connections**

Once the NMEA 2000<sup>®</sup>/Power and/or NMEA 0183 connections to the Maretron SSC200 have been completed, check to see that heading information is being properly transmitted by observing an appropriate display. Refer to Section 7, "Troubleshooting", if no heading information appears, otherwise proceed to Section 3 entitled "Calibration".

## **3 Calibration**

In order to provide accurate heading indication, the SSC200 must be calibrated in the vessel after installation. The two calibration procedures that must be carried out are magnetic deviation calibration (Section 3.1) and installation-offset correction (Section 3.2).

These procedures should be carried out after the initial compass installation and again at any time that the magnetic environment of the vessel has changed significantly (for example, new cables have been routed near the compass or new equipment made of ferrous metal has been installed near the compass).

***WARNING: It is imperative that calibration procedures be carried out upon installation of the SSC200 to ensure accurate readings.***

### **3.1 Magnetic Deviation Calibration**

Magnetic and/or ferrous items near a magnetic compass such as the SSC200 can cause errors in the compass' heading output. These errors are referred to as magnetic deviation.

The Maretron SSC200 compass can compensate for heading errors caused by magnetic deviation by learning about the magnetic environment in which it has been mounted. This is done using one of four possible magnetic deviation calibration procedures.

1. Maretron Display Product Initiated (Section 3.1.1)
2. Automatically at Power-Up (Section 3.1.2)
3. Through the NMEA 0183 Interface (Appendix A)
4. Through the NMEA 2000<sup>®</sup> Interface (Appendix B)

All the procedures require that the vessel be turned in successive circles during which time the SSC200 uses changing heading information along with readings from the angular rate sensor to calculate hard and soft iron magnetic deviation. Upon a successful completion of deviation calibration, the SSC200 stores the deviation values in permanent memory for subsequent compensation. Under certain conditions (e.g., turning to fast or to slow), the SSC200 will not

successfully complete the calibration process and the SSC200 will not store the deviation values in its permanent memory. Therefore, it is important to verify that the deviation calibration process completed successfully.

The preferred method for deviation calibration is to use a Maretron display (procedure 1) because you receive direct feedback on the calibration process with a clear indication of a successful or unsuccessful deviation calibration. Deviation calibration done automatically at power-up (procedure 2) is less desirable than procedure 1 because it is more difficult to verify that a successful deviation calibration completed. As an alternative to procedures 1 and 2, users with direct access to the NMEA 0183 and NMEA 2000® interfaces can perform magnetic deviation calibration directly through the NMEA 0183 interface (see Appendix A) or the NMEA 2000® interface (see Appendix B). These direct access methods also provide an indication of a successful deviation calibration or an indication of an unsuccessful deviation calibration and the corresponding reason for the failure.

### **3.1.1 Maretron Display Initiated Deviation Calibration**

Maretron display initiated deviation calibration is accomplished by turning the vessel through successive circles while the SSC200 receives a command from a Maretron display product (e.g., DSM200). The procedure is as follows:

1. Ensure that the compass has been properly installed per Section 2.
2. Warm up the compass by operating it for approximately 10 minutes.
3. Turn the vessel (either direction) such that you complete a full 360° turn in 2½ minutes or less (try not to go below 1 minute for a complete circle).
4. While continuing to turn the vessel as indicated in step 3, use the display's menu items to locate and send the deviation calibration command (please refer to the display product user's manual).
5. Continue turning the vessel through at least three complete circles until the display indicates a successful deviation calibration.

While turning the vessel, try to maintain a circle by holding the rudder at a constant angle. In addition, try to minimize the vessel's pitch and roll by calibrating on calm, flat water.

After deviation calibration is complete, the results of the deviation calibration, which indicate the quality of the compass installation environment, may be seen using a Maretron display product (e.g., DSM200 - please refer to the DSM200 user's manual for details). This allows you to compare different installation points on a vessel to determine the optimum location for the SSC200.

### **3.1.2 Automatic Power-Up Deviation Calibration**

Automatic power-up deviation calibration is accomplished by turning the vessel through four complete circles within 10 minutes of power-up. The procedure is as follows:

1. Ensure that the compass has been properly installed per Section 2.
2. Warm up the compass by operating it for approximately 10 minutes.

3. Turn the vessel (either direction) such that you complete a full 360° turn in 2½ minutes or less (try not to go below 1 minute for a complete circle).
4. While continuing to turn the vessel as indicated in step 3, remove the power from the compass and reapply power (this initiates deviation calibration).
5. Continue turning the vessel through four complete circles in less than 10 minutes from the time power was applied.
6. Successful deviation is indicated when the SSC200 outputs the following sequence:
  - a) 0 Degrees for two seconds followed by
  - b) 90 degrees for two seconds followed by
  - c) 180 degrees for two seconds followed by
  - d) 270 degrees for two seconds followed by the actual heading

While turning the vessel, try to maintain a circle by holding the rudder at a constant angle. In addition, try to minimize the vessel's pitch and roll by calibrating on calm, flat water.

### **3.2 Installation-Offset Correction**

After installation and successful deviation calibration, it is important to perform installation-offset correction so that the displayed compass heading, pitch, and roll match the actual vessel heading, pitch, and roll. Installation-offset correction is done using one of four possible procedures.

1. Maretron Display Product Initiated (Section 3.2.1)
2. Manual Installation-Offset Correction (Section 3.2.2)
3. Through the NMEA 0183 Interface (Appendix A)
4. Through the NMEA 2000<sup>®</sup> Interface (Appendix B)

The preferred method for installation-offset is to use a Maretron display (procedure 1) which will automatically calibrate the SSC200 without physically adjusting the compass as describe under procedure 2 (Manual Installation-Offset Correction). As an alternative to procedures 1 and 2, users with direct access to the NMEA 0183 and NMEA 2000<sup>®</sup> interfaces can perform installation-offset correction through the NMEA 0183 interface (see Appendix A) or the NMEA 2000<sup>®</sup> interface (see Appendix B).

#### **3.2.1 Maretron Display Product Offset Correction**

Installation-offset correction can be performed using a Maretron display product (e.g., DSM200). The procedure is as follows:

1. Make sure the vessel is laying in flat water on a known heading.
2. Use the display's menu items to locate and send the compass installation-offset correction command (please refer to display product user's manual).

#### **3.2.2 Manual Installation-Offset Correction**

Manual installation-offset correction is performed by physically aligning the compass with the vessel. The procedure is as follows:

1. With the vessel laying flat in the water, adjust the roll angle of the SSC200 by adding small washers or spacers between the mounting bracket holes and mounting surface



- until the display reads zero for the roll angle (skip this step if you are not interested in viewing the vessel's roll angle).
2. With the vessel laying flat in the water, adjust the pitch angle of the SSC200 by adding small washers or spacers between the mounting bracket holes and mounting surface until the display reads zero for the pitch angle (skip this step if you are not interested in viewing the vessel's pitch angle).
  3. With the vessel laying flat in the water on a known heading, adjust the heading of the SSC200 by rotating it until the display reads the known vessel heading.
  4. Recheck that the roll and pitch readings are zero and that the indicated heading is correct (repeat steps 1 through 3 as necessary).
  5. Securely fasten the SSC200 by tightening the mounting screws.

## 4 Variation

Variation is the angular difference between the true meridian (great circle connecting the geographic poles) and the magnetic meridian (direction of the lines of magnetic flux). Variation has different values at different locations on the earth with most areas undergoing change to the variation over time.

Normally, heading information is displayed as either a “true” heading (a direction relative to the geographic poles) or it is displayed as a “magnetic” heading (a direction relative to the lines of magnetic flux). North-seeking gyrocompasses are capable of measuring direction relative to the geographic poles (“true”) whereas magnetic compasses measure direction relative to the earth's local magnetic flux (“magnetic”).

The SSC200 is a magnetic compass; therefore, it requires an external source for variation if you want to view your heading in “true” format. The SSC200 is capable of receiving variation in one of three ways; 1) via the NMEA 0183 interface, 2) via the NMEA 2000® interface, or 3) through manual variation entry.

Normally, the SSC200 will automatically use variation from either the NMEA 0183 interface or the NMEA 2000® interface, however, you can force the SSC200 to use variation from only the NMEA 0183 interface or you can force the SSC200 to use variation from only the NMEA 2000® interface or you can force SSC200 to only use manually entered variation.

***WARNING: Multiple variation sources that are received by the SSC2000 (i.e., NMEA 0183 and NMEA 2000® interfaces) will cause confusion as to the correct source to be used for true heading indications. If more than one variation source is available, then the SSC200 needs to be programmed to use the appropriate source for reporting subsequent true heading information. See Section 4.4 for details on choosing a specific variation source when more than one variation source is available.***

### 4.1 Variation Input via NMEA 0183 Interface

As shipped from the factory, the SSC200 automatically looks for variation data coming from the NMEA 0183 interface. The SSC200 accepts variation data from the Recommended Minimum Specific GNSS Data (RMC) sentence or the SSC200 computes variation from the

Course Over Ground and Ground Speed (VTG) sentence. If the SSC200 does indeed receive variation information from the NMEA 0183 interface, then it will do the following:

1. Transmit the Heading, Deviation & Variation (HDG) sentence including the variation field as seen from the RMC or VTG sentence over the NMEA 0183 interface if HDG is enabled (see Appendix A for enabling or disabling NMEA 0183 sentences).
2. Transmit the Heading True (HDT) sentence using variation data from the RMC or VTG sentence over the NMEA 0183 interface if HDT is enabled (see Appendix A for enabling or disabling NMEA 0183 sentences).
3. Transmit over the NMEA 2000<sup>®</sup> interface the Magnetic Variation PGN (127258) with the Variation Source field value corresponding to the received NMEA 0183 variation data from the RMC or VTG sentence. The PGN's Variation Source field will be transmitted with the lowest possible quality indicator, which is "Manual Entry".

### **4.2 Variation Input via the NMEA 2000<sup>®</sup> Interface**

As shipped from the factory, the SSC200 automatically looks for variation data coming from the NMEA 2000<sup>®</sup> interface. The SSC200 accepts variation data from the Magnetic Variation PGN (127258). If the SSC200 does indeed receive variation information from the NMEA 2000<sup>®</sup> interface, then it will do the following:

1. Transmit the Heading, Deviation & Variation (HDG) sentence including the variation field as seen from the Magnetic Variation PGN (127258) from the NMEA 2000 interface if HDG is enabled (see Appendix A for enabling or disabling NMEA 0183 sentences).
2. Transmit the Heading True (HDT) sentence using variation data from the Magnetic Variation PGN (127258) from the NMEA 2000 interface if HDT is enabled (see Appendix A for enabling or disabling NMEA 0183 sentences).

### **4.3 Variation Input via Manual Entry**

If no other source of variation is available (i.e., from either the NMEA 0183 or NMEA 2000<sup>®</sup> interface), the SSC200 can be programmed with a fixed variation value for a given location (this value can be found on most navigational charts). If variation is manually entered into the SSC200, then it will do the following:

1. Transmit the Heading, Deviation & Variation (HDG) sentence including the variation field as manually entered over the NMEA 0183 interface if HDG is enabled (see Appendix A for enabling or disabling NMEA 0183 sentences).
2. Transmit the Heading True (HDT) sentence using variation data as manually entered over the NMEA 0183 interface if HDT is enabled (see Appendix A for enabling or disabling NMEA 0183 sentences).
3. Transmit over the NMEA 2000<sup>®</sup> interface the Magnetic Variation PGN (127258) with the Variation Source field value corresponding to the manually entered variation. The PGN's Variation Source field will be transmitted with the lowest possible quality indicator, which is "Manual Entry".

***WARNING: Magnetic variation changes as your position on the earth changes; therefore, the variation should be adjusted with changes in position. The SSC200 will***

*not automatically adjust variation with changes in position; it is the responsibility of the user to adjust variation with changes in position.*

## 4.4 Variation Source Selection

As shipped from the factory, the SSC200 automatically looks for variation from both the NMEA 0183 and NMEA 2000® interfaces. If there is only a single source of variation available (either from the NMEA 0183 or the NMEA 2000® interface), then there is no need to manually select a variation source. However, if there are multiple variation sources (i.e., variation available from both the NMEA 0183 and NMEA 2000® interfaces) or there is no source for variation (i.e., variation is not available from either the NMEA 0183 or the NMEA 2000® interfaces), then it is necessary to select a particular variation source. The SSC200 can be programmed to specifically use one of three possible variation sources:

1. Variation from Only NMEA 0183 Interface
2. Variation from Only NMEA 2000® Interface
3. Variation from Only Manual Entry

The SSC200 can be programmed to accept a specific source for the variation data using one of two possible procedures.

1. Using a Maretron Display (Section 4.4.1)
2. Through the NMEA 0183 Interface (Section 4.4.2)

### 4.4.1 Variation Source Selection via Maretron Display

You can program the SSC200 to use a particular variation source using a Maretron display product (e.g., DSM200). Refer to the display product user's manual for details on programming the SSC200 to use a specific variation source.

### 4.4.2 Variation Source Selection via NMEA 0183 Interface

You can program the SSC200 to use a particular variation source through the NMEA 0183 interface. Refer to Appendix A for details on programming the SSC200 to use a specific variation source.

## 5 Rate of Turn

The SSC200 is capable of measuring a vessel's rate of turn and outputting the information over both the NMEA 0183 and NMEA 2000® interfaces. Furthermore, the SSC200 has a programmable damping period where the filter time can be increased for very slow turning vessels such as tugs pushing barges. Also, the SSC200 rate of turn indication may be zeroed to correct for any temperature-induced offset.

The SSC200 can be programmed with different damping periods and have the rate of turn indication zeroed using one of two possible procedures.

1. Using a Maretron Display (Section 5.1)
2. Through the NMEA 0183 Interface (Section 5.2)

### **5.1 Rate of Turn Damping Period Selection with Maretron Display**

You can program the SSC200 to use a particular rate of turn damping period using a Maretron display product (e.g., DSM200). Refer to the display product user's manual for details on programming the SSC200 to use a specific damping period.

### **5.2 Rate of Turn Damping Period Selection by NMEA 0183 Interface**

You can program the SSC200 to use a particular rate of turn damping period through the NMEA 0183 interface. Refer to Appendix A for details on programming the SSC200 to use a specific damping period.

### **5.3 Rate of Turn Zeroing**

The SSC200 may be used as a rate of turn indicator, which should read zero when the vessel is not turning. It is possible that the rate of turn indication has an offset; that is, it may show a non-zero value when the vessel is at rest. This offset changes with temperature but the SSC200 has the ability to remember the offset at different temperatures. You teach the SSC200 by using "Rate of Turn Zeroing". It is possible to do "Rate of Turn Zeroing" using a Maretron display product, such as the DSM200 (please refer to the display product user's manual for details).

## **6 Maintenance**

Regular maintenance is important to ensure continued proper operation of the Maretron SSC200. Perform the following tasks periodically:

- Clean the unit with a soft cloth. Do not use chemical cleaners as they may remove markings or may corrode the compass enclosure or seals.
- Ensure that the unit is mounted securely and cannot be moved relative to the mounting surface. If the unit is loose, tighten the mounting screws and repeat the magnetic deviation calibration and installation-offset correction.
- Check the security of the cables connected to the NMEA 2000® and/or NMEA 0183 interfaces and tighten if necessary.

## 7 Troubleshooting

If you notice unexpected operation of the Maretron SSC200, follow the troubleshooting procedures in this section to remedy simple problems.

Symptom	Troubleshooting Procedure
No heading output	<p>Check the connections to the NMEA 2000®/Power connector and/or NMEA 0183 Connector and tighten if necessary</p> <p>Ensure that power is supplied to the connected NMEA 2000® or NMEA 0183 cable</p> <p>For NMEA 0183 connections, ensure that the SSC200 is programmed to transmit the appropriate type of sentence (HDT, HDG, or HDM) required by the connected equipment.</p> <p>If the HDT sentence is being transmitted, ensure that the SSC200 is provided with a source of magnetic variation information so that it can calculate true heading from the magnetic heading.</p>
Inaccurate heading output	<p>Ensure the SSC200 is still mounted securely</p> <p>Ensure the SSC200 is still in a clean magnetic environment and that no power or ignition cables or magnetic or ferrous objects have been moved near the SSC200</p> <p>Repeat the magnetic deviation compensation and installation-offset correction procedures</p>

**Figure 9 – Trouble Shooting Guide**

If these steps do not solve your problem, please contact Maretron Technical Support (refer to Section 9 for contact information).

**Warning: There are no user-serviceable components inside the Maretron SSC200. Opening the SSC200 will expose the sensitive electronic components to movement and adverse environmental conditions that may render the compass inoperative. Please do not open the SSC200, as this will automatically void the warranty. If service is required, please return the unit to an authorized Maretron service location.**

## 8 Technical Specifications

### Specifications

Parameter	Value	Comment
Static Heading Accuracy	<1° rms	±45° Pitch and Roll - 15°C to 35°C
Heading Display Resolution	0.1°	With Maretron Display
Settling Time	1 Second	To Static Accuracy after 35°/Second Turn
Heading Deviation	Yes	Automatic or Initiated through Interfaces
Alignment Calibration	Yes	Manual or Initiated through Interfaces
Pitch and Roll Range	±80°	
Pitch and Roll Accuracy	<1°	±45° Pitch and Roll - 15°C to 35°C
Pitch and Roll Display Resolution	0.1°	With Maretron Display
Pitch and Roll to Boat Alignment	Yes	Manual or Initiated through Interfaces
Rate of Turn Range	0° - 90° per Second	
Rate of Turn Accuracy	±1° per Second	0° Pitch and Roll - 15°C to 35°C

### Certifications

Parameter	Comment
NMEA 2000	Level A
Maritime Navigation and Radiocommunication Equipment & Systems	Tested to IEC 60945
FCC and CE Mark	Electromagnetic Compatibility

### NMEA 2000® Parameter Group Numbers (PGNs) - See Appendix B for Details

Description	PGN #	PGN Name	Default Rate
Periodic Data PGNs	127250	Vessel Heading	10 Times/Second
	127257	Attitude	1 Time/Second
	127251	Rate of Turn	10 Times/Second
Response to Requested PGNs	126464	PGN List (Transmit and Receive)	N/A
	126996	Product Information	N/A
	126998	Configuration Information	N/A
Protocol PGNs	059392	ISO Acknowledge	N/A
	059904	ISO Request	N/A
	060416	ISO Transport Protocol, Connection Management	N/A
	060160	ISO Transport Protocol, Data Transfer	N/A
	060928	ISO Address Claim	N/A
	065240	ISO Address Command	N/A
	126206	NMEA	N/A

### NMEA 0183 Sentences - See Appendix A for Details

Description	Acronym	Sentence Name	Default Rate
Transmitted Sentences	HDG	Heading, Deviation, and Variation	10 Times/Second
	HDM	Heading, Magnetic (Not normally transmitted, see Appendix A)	N/A
	HDT	Heading True (Not normally transmitted, see Appendix A)	N/A
	ROT	Rate of Turn	5 Times/Second
	PMAROUT	Maretron Proprietary Attitude (Pitch and Roll)	1 Time/Second
	TXT	Text Transmission	N/A
Received Sentences	RMC	Recommended Minimum Specific GNSS Data	N/A
	VTG	Course Over Ground and Ground Speed	N/A

## Electrical

Parameter	Value	Comment
Operating Voltage	9 to 16 Volts	DC Voltage
Power Consumption	<150mA	Average Current Drain
Load Equivalence Number (LEN)	3	NMEA 2000® Spec. (1LEN = 50 mA)
Reverse Battery Protection	Yes	Indefinitely
Load Dump Protection	Yes	Energy Rated per SAE J1113

## Mechanical

Parameter	Value	Comment
Size	4.46" x 3.23" x 2.14"	Including Mounting Flanges
Weight	7 oz.	
Mounting	Deck or Bulkhead	

## Environmental

Parameter	Value
IEC 60954 Classification	Exposed
Degree of Protection	IP67
Operating Temperature	-25°C to 55°C
Storage Temperature	-40°C to 70°C
Relative Humidity	93%RH @40° per IEC60945-8.2
Vibration	2-13.2Hz @ ±1mm, 13.2-100Hz @ 7m/s <sup>2</sup> per IEC 60945-8.7
Rain and Spray	12.5mm Nozzle @ 100liters/min from 3m for 30min per IEC 60945-8.8
Solar Radiation	Ultraviolet B, A, Visible, and Infrared per IEC 60945-8.10
Corrosion (Salt Mist)	4 times 7days @ 40°C, 95%RH after 2 hour Salt Spray Per IEC 60945-8.12
Electromagnet Emission	Conducted and Radiated Emission per IEC 60945-9
Electromagnetic Immunity	Conducted, Radiated, Supply, and ESD per IEC 60945-10
Safety Precautions	Dangerous Voltage, Electromagnetic Radio Frequency per IEC 60945-12

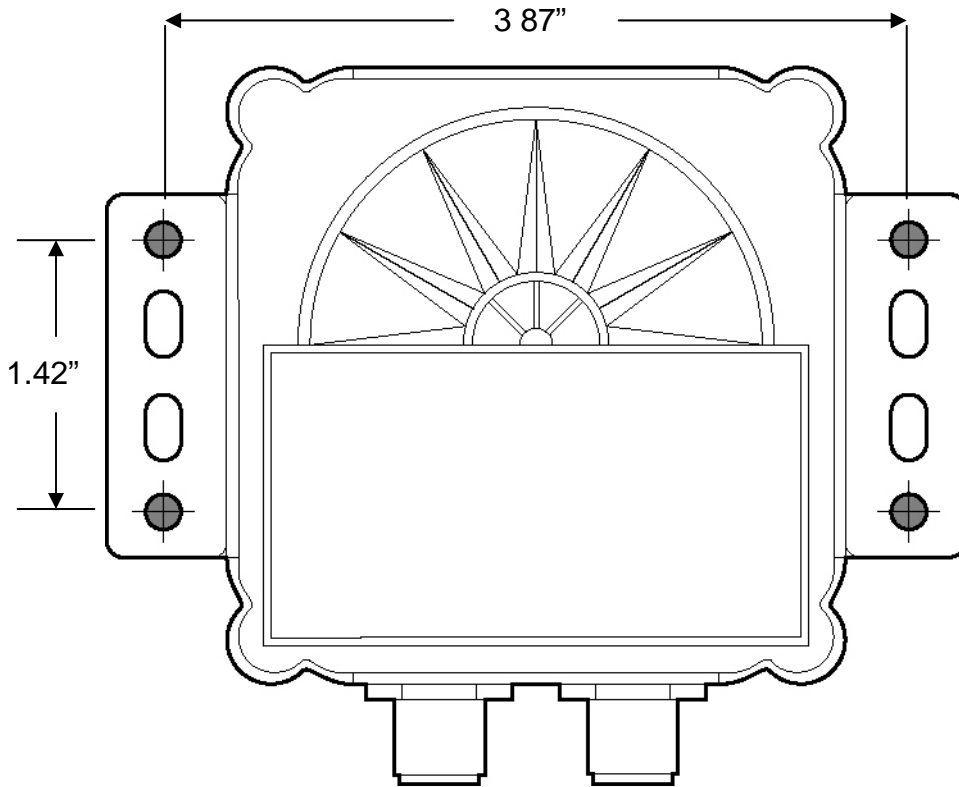
## 9 Technical Support

If you require technical support for Maretron products, you can reach us in one of the following ways:

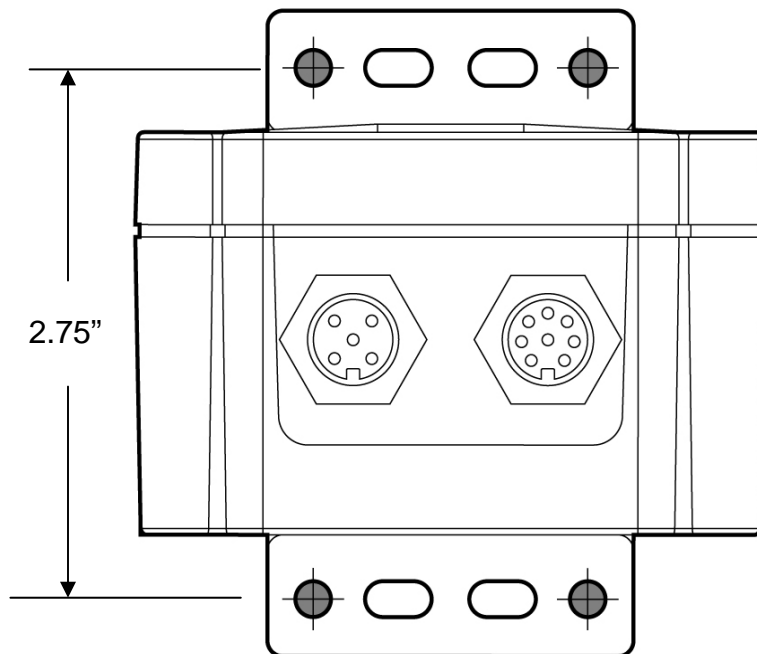
Telephone: 1-866-550-9100  
Fax: 1-602-861-1777  
E-mail: [support@maretron.com](mailto:support@maretron.com)  
World Wide Web: <http://www.maretron.com>  
Mail: Maretron, LLC  
Attn: Technical Support  
9034 N. 23<sup>rd</sup> Ave Suite 13  
Phoenix, AZ 85021 USA

## 10 Installation Template

Please check the dimensions before using the following diagrams as templates for drilling the mounting holes because the printing process may have distorted the dimensions.



**Figure 10 – Horizontal Mounting Surface Template**



**Figure 11 – Vertical Mounting Surface Template**



## 11 Maretron (2 Year) Limited Warranty

Maretron warrants the SSC200 to be free from defects in materials and workmanship for **two (2) years** from the date of original purchase. If within the applicable period any such products shall be proved to Maretron's satisfaction to fail to meet the above limited warranty, such products shall be repaired or replaced at Maretron's option. Purchaser's exclusive remedy and Maretron's sole obligation hereunder, provided product is returned pursuant to the return requirements below, shall be limited to the repair or replacement, at Maretron's option, of any product not meeting the above limited warranty and which is returned to Maretron; or if Maretron is unable to deliver a replacement that is free from defects in materials or workmanship, Purchaser's payment for such product will be refunded. Maretron assumes no liability whatsoever for expenses of removing any defective product or part or for installing the repaired product or part or a replacement therefore or for any loss or damage to equipment in connection with which Maretron's products or parts shall be used. With respect to products not manufactured by Maretron, Maretron's warranty obligation shall in all respects conform to and be limited to the warranty actually extended to Maretron by its supplier. The foregoing warranties shall not apply with respect to products subjected to negligence, misuse, misapplication, accident, damages by circumstances beyond Maretron's control, to improper installation, operation, maintenance, or storage, or to other than normal use or service.

THE FOREGOING WARRANTIES ARE EXPRESSLY IN LIEU OF AND EXCLUDES ALL OTHER EXPRESS OR IMPLIED WARRANTIES, INCLUDING BUT NOT LIMITED TO THE IMPLIED WARRANTIES OF MERCHANTABILITY AND OF FITNESS FOR A PARTICULAR PURPOSE.

Statements made by any person, including representatives of Maretron, which are inconsistent or in conflict with the terms of this Limited Warranty, shall not be binding upon Maretron unless reduced to writing and approved by an officer of Maretron.

IN NO CASE WILL MARETRON BE LIABLE FOR INCIDENTAL OR CONSEQUENTIAL DAMAGES, DAMAGES FOR LOSS OF USE, LOSS OF ANTICIPATED PROFITS OR SAVINGS, OR ANY OTHER LOSS INCURRED BECAUSE OF INTERRUPTION OF SERVICE. IN NO EVENT SHALL MARETRON'S AGGREGATE LIABILITY EXCEED THE PURCHASE PRICE OF THE PRODUCT(S) INVOLVED. MARETRON SHALL NOT BE SUBJECT TO ANY OTHER OBLIGATIONS OR LIABILITIES, WHETHER ARISING OUT OF BREACH OF CONTRACT OR WARRANTY, TORT (INCLUDING NEGLIGENCE), OR OTHER THEORIES OF LAW WITH RESPECT TO PRODUCTS SOLD OR SERVICES RENDERED BY MARETRON, OR ANY UNDERTAKINGS, ACTS OR OMISSIONS RELATING THERETO.

Maretron does not warrant that the functions contained in any software programs or products will meet purchaser's requirements or that the operation of the software programs or products will be uninterrupted or error free. Purchaser assumes responsibility for the selection of the software programs or products to achieve the intended results, and for the installation, use and results obtained from said programs or products. No specifications, samples, descriptions, or illustrations provided Maretron to Purchaser, whether directly, in trade literature, brochures or other documentation shall be construed as warranties of any kind, and any failure to conform with such specifications, samples, descriptions, or illustrations shall not constitute any breach of Maretron's limited warranty.

### **Warranty Return Procedure:**

To apply for warranty claims, contact Maretron or one of its dealers to describe the problem and determine the appropriate course of action. If a return is necessary, place the product in its original packaging together with proof of purchase and send to an Authorized Maretron Service Location. You are responsible for all shipping and insurance charges. Maretron will return the replaced or repaired product with all shipping and handling prepaid except for requests requiring expedited shipping (i.e. overnight shipments). Failure to follow this warranty return procedure could result in the product's warranty becoming null and void.

Maretron reserves the right to modify or replace, at its sole discretion, without prior notification, the warranty listed above. To obtain a copy of the then current warranty policy, please go to the following web page:

<http://www.maretron.com/company/warranty.php>



## Appendix A – NMEA 0183 Interfacing

### SSC200 NMEA 0183 Transmitted Sentences

#### ***HDG – Heading, Deviation & Variation***

The SSC200 indicates heading 10 times a second. The deviation field always contains zero as the SSC200 reports it's heading with the deviation included. The variation field will normally contain the null character, however if the SSC200 receives either a valid RMC or VTG sentence, then the SSC200 will fill the variation field appropriately.

`$IHDG,A,B,C,D,E*hh<CR><LF>`

Field A: Magnetic heading sensor including deviation in tenths of degrees

B: Deviation always reads 0.0 because it is included in field A

C: Although this field reads as "E", it is meaningless as the deviation is always zero

D: Null unless receiving variation data from RMC or VTG sentence in which case variation data

E: Null unless receiving variation data from RMC or VTG sentence in which case E or W depending on direction of variation

#### ***HDM – Heading, Magnetic***

The SSC200 does not normally transmit this sentence because it is no longer recommended for new designs by NMEA. However, this sentence can be enabled or turned on via a proprietary NMEA 0183 sentence (see \$PMARSETP definition).

`$IHDM,A,B*hh<CR><LF>`

Field A: Magnetic heading sensor including deviation in tenths of degrees

B: This field always contains an "M" indicating magnetic heading

#### ***HDT – Heading, True***

The SSC200 does not normally transmit this sentence. However, this sentence can be enabled or turned on via a proprietary NMEA 0183 sentence (see \$PMARSETP definition). The HDT sentence works in collaboration with the reception of an RMC or VTG sentence to produce true heading.

`$IHDT,A,B*hh<CR><LF>`

Field A: Null unless receiving variation from RMC and VTG in which case magnetic heading including deviation and variation in tenths of degrees

B: This field always contains a "T" indicating true magnetic heading

#### ***ROT – Rate of Turn***

The SSC200 indicates the vessel's rate of turn 5 times a second.

`$IROT,A,B*hh<CR><LF>`

Field A: Rate of turn in degrees/minute where "-" indicates the bow turning to port

B: This field indicates whether data is valid, an "A" indicates that the data is valid where a "V" indicates invalid data

#### ***MAROUT – Maretron Proprietary Output Sentence***

Since there is no standard NMEA 0183 sentence for indicating the vessel's attitude (pitch and roll), the SSC200 uses a proprietary sentence to indicate pitch and roll one time per second.

`$PMAROUT,A,B,C,D,E,F,G,H,I*hh<CR><LF>`

Field A: Always reads "ATT" to indicate following data is associated with the vessel's attitude

B: Roll angle in tenths of degrees, where "-" indicates roll to the port

C: Pitch angle in tenths of degrees, where "-" indicates bow pitches downward

# SSC200 User's Manual

---

D-I: Null

## **TXT – Text Transmission**

The SSC200 transmits various status messages using the text transmission sentence.

`$IITXT,A,B,C,D*hh<CR><LF>`

Field A: Always reads "01"

B: Always reads "01"

C: Message identifier (see following table)

D: Text string (see following table)

Message Identifier	Text String	Description
01	Deviation Calibration Started	This message is transmitted at the beginning of the magnetic deviation calibration process.
02	Deviation Calibration Completed Successfully	This message is transmitted upon successful completion of the magnetic deviation calibration process (i.e., a new deviation table has been stored in permanent memory).
03	Deviation Calibration Failed to Complete	The SSC200 attempts to perform calibration 5 times before giving up and issuing this sentence. Each time the SSC200 encounters an error (see message identifiers 04, 05, and 06) it restarts the calibration process. Upon the 5 <sup>th</sup> error, the SSC200 exits the calibration routine and it must be restarted before it will once again try to perform deviation calibration.
04	Deviation Calibration Turning Too Fast	During calibration, the vessel must not turn to fast where the SSC200 is unable to reliably develop deviation data. If the SSC200 senses the vessel turning to quickly, it will issue this message and restart deviation calibration as long as it has not failed five times.
05	Deviation Calibration Turning Too Slow	During calibration, the vessel must not turn to slowly where the SSC200 is unable to reliably develop deviation data. If the SSC200 senses the vessel turning to slowly, it will issue this message and restart deviation calibration as long as it has not failed five times.
06	Deviation Calibration Invalid Movement	During calibration, the vessel must not jerk or reverse directions where the SSC200 is unable to reliably develop deviation data. If the SSC200 senses an invalid movement, it will issue this message and restart deviation calibration as long as it has not failed five times.
95	Serial Number: xxxxxxx	The SSC200 transmits this sentence once after it is powered up to indicate its serial number.
96	Baud Rate: 4800	The SSC200 transmits this sentence once after it is powered up to indicate its baud rate.
97	SW Version: 1.2	The SSC200 transmits this sentence once after it is powered up to indicate its software version.
98	Model Version: 1.0	The SSC200 transmits this sentence once after it is powered up to indicate its model version.
99	Model ID: SSC200	The SSC200 transmits this sentence once after it is powered up to indicate its model identification.

## SSC200 NMEA 0183 Received Sentences

### **Note on NMEA 0183 Checksums**

For ease of manual configuration of the SSC200 via the NMEA 0183 Interface, NMEA 0183 checksums are optional. If no checksum is present in a received sentence, then the sentence is treated as if a valid checksum were present. If a checksum is present in a received sentence, then it is used to check the integrity of the sentence, which is accepted only if the calculated checksum agrees with the checksum at the end of the received sentence. To ensure the best possible data integrity, Maretron recommends using NMEA 0183 checksums whenever possible.

### **RMC – Recommended Minimum Specific GNSS Data**

The SSC200 is capable of receiving the RMC sentence and extracting the magnetic variation data for subsequent insertion into the appropriate fields for transmission of the HDG and HDT sentences. The SSC200 uses an aging technique (referred to as “Variation Lifetime”) where variation data is output in the HDG and HDT sentences for a period of 5 seconds after the RMC sentence is received. The Variation Lifetime can be re-programmed to a shorter or longer period (see PMARSETP sentence).

### **VTG – Course Over Ground and Ground Speed**

The SSC200 is capable of receiving the VTG sentence and computing the magnetic variation data for subsequent insertion into the appropriate fields for transmission of the HDG and HDT sentences. The variation is computed by observing the difference between the true course over ground and the magnetic course over ground. The SSC200 uses an aging technique (referred to as “Variation Lifetime”) where variation data is output in the HDG and HDT sentences for a period of 5 seconds after the VTG sentence is received. The Variation Lifetime can be re-programmed to a shorter or longer time period (see PMARSETP sentence).

### **PMAREXE – Maretron Proprietary Execute Sentence**

The SSC200 can be commanded via this proprietary sentence to execute one of several commands.

`$PMAREXE,SSC200,,F0,,,<CR><LF>`

This command causes the SSC200 to be reset and is useful for initiating deviation calibration.

`$PMAREXE,SSC200,,FD,0,,,<CR><LF>`

This command causes the SSC200 to stop outputting normal periodic data (like heading) and is useful for observing non-periodic sentences such as status sentences during deviation calibration.

`$PMAREXE,SSC200,,FD,1,,,<CR><LF>`

This command causes the SSC200 to once again output periodic data. Normally, periodic data is disabled during the calibration process such that status messages are easy to see and not lost within normal periodic data. This sentence is used to turn the periodic data back on.

`$PMAREXE,SSC200,,24,"known heading in tenths of degrees",,,,<CR><LF>`

This is the command used to perform installation-offset where the compass is aligned to a known heading and the pitch and roll are zeroed to the vessel's current attitude. If the current or known heading is 177.0°, then a value of 1770 should be programmed.

`$PMAREXE,SSC200,,5D,0,"variation",,<CR><LF>`

This command causes the SSC200 to use a manual entry for variation (variation is programmed using 1/10 of a degree resolution – as an example use 2.3 in the “variation” field for a 2.3° variation).

`$PMAREXE,SSC200,,5D,1,,,<CR><LF>`

This command causes the SSC200 to use variation data from the NMEA 2000® interface and ignore all other variation sources (i.e., NMEA 0183 interface and manual entries).

# SSC200 User's Manual

---

`$PMAREXE,SSC200,,5D,2,,,<CR><LF>`

This command causes the SSC200 to use variation data from the NMEA 0183 interface and ignore all other variation sources (i.e., NMEA 2000<sup>®</sup> interface and manual entries).

`$PMAREXE,SSC200,,5D,3,,,<CR><LF>`

This command causes the SSC200 to use resort back to the factory default where variation data is used from either the NMEA 0183 interface or the NMEA 2000<sup>®</sup> interface.

`$PMAREXE,SSC200,,5E,2,"damping period",,<CR><LF>`

This command causes the SSC200 to use a rate of turn damping rate corresponding to the value programmed in "damping period". The damping period is programmable from 100 to 60000, which represents 100ms to 60 seconds.

`$PMAREXE,SSC200,,5E.11,,,<CR><LF>`

This command causes the SSC200 to zero the rate of turn indication and record the compensation value used, along with the current operating temperature of the compass. The boat must remain at rest for a period of one minute after this command is issued.

`$PMAREXE,SSC200,,5E.12,,,<CR><LF>`

This command causes the SSC200 to cancel any rate of turn zeroing operations currently in progress.

## **PMARSETPX – Maretron Proprietary Set Period Sentence**

The SSC200 can be programmed to enable or disable the periodic transmission of the HDG, HDM, HDT, ROT, and PMAROUT sentences. In addition, the periodic transmission rate for these sentences and the Variation Lifetime (see RMC and VTG) can be programmed using this sentence.

`$PMARSETPX,SSC200,,A,B*hh<CR><LF>`

Field A: Identifier code, identifies the sentence or parameter to be programmed (see following table)

B: Integer where "0" disables sentence and positive numbers are multipliers of 1ms (i.e., programmed integer of 200 would mean a 200ms transmission interval)

Identifier Code	Sentence	Default Rate
00	HDG	100 (100ms)
01	HDM	0 or Disabled
02	HDT	0 or Disabled
03	ROT	200 or 200ms
04	PMAROUT	1000 or 1sec
0A	Variation Lifetime	5000 or 5sec

Some example sentences are shown below:

1. To disable transmission of the HDG sentence:  
`$PMARSETPX,SSC200,,00,0`
2. To enable transmission of the HDG sentence at intervals of 100 ms:  
`$PMARSETPX,SSC200,,00,100`
3. To disable transmission of the HDM sentence:  
`$PMARSETPX,SSC200,,01,0`
4. To enable transmission of the HDM sentence at intervals of 1000 ms:  
`$PMARSETPX,SSC200,,01,1000`
5. To disable transmission of the HDT sentence:  
`$PMARSETPX,SSC200,,02,0`

6. To enable transmission of the HDT sentence at intervals of 100 ms:  
\$PMARSETPX,SSC200,,02,100
7. To disable transmission of the ROT sentence:  
\$PMARSETPX,SSC200,,03,0
8. To enable transmission of the ROT sentence at intervals of 100 ms:  
\$PMARSETPX,SSC200,,03,100
9. To disable transmission of the PMAROUT sentence:  
\$PMARSETPX,SSC200,,04,0
10. To enable transmission of the PMAROUT sentence at intervals of 1 sec:  
\$PMARSETPX,SSC200,,04,1000

\$PMARSETPX,SSC200,,A,B\*hh<CR><LF>

Field A: Identifier code, identifies the sentence or parameter to be programmed (see following table)

B: Integer where "0" disables sentence and positive numbers are multipliers of 1ms (i.e., programmed integer of 2 would mean a 200ms transmission interval)

Identifier Code	Sentence	Default Rate
00	HDG	1 or 100ms
01	HDM	0 or Disabled
02	HDT	0 or Disabled
03	ROT	2 or 200ms
04	PMAROUT	10 or 1sec
0A	Variation Lifetime	50 or 5sec

## **SSC200 NMEA 0183 Initiated Deviation Calibration**

NMEA 0183 initiated deviation calibration is accomplished by turning the vessel through at least 3 complete circles after the SSC200 receives a Maretron proprietary NMEA 0183 sentence. The procedure is as follows:

1. Ensure that the compass has been properly installed per Section 2,
2. Warm up the compass by operating it for approximately 10 minutes,
3. Turn the vessel (either direction) such that you complete a full 360° turn in 2½ minutes or less (try not to go below 1 minute for a complete circle),
4. Send the following Maretron proprietary NMEA0183 sentence to the SSC200 while continuing to turn the vessel:
  - a. \$PMAREXE,SSC200,,FD,0,,,<CR><LF> This will turn off all periodic transmissions such that you can easily see status messages associated with the calibration process
  - b. \$PMAREXE,SSC200,,F0,,,<CR><LF> This will initiate a reset and force the SSC200 to start the calibration process
5. Continue turning the vessel through at least 3 circles until you see one of the following Maretron proprietary sentences:
  - a. \$IITXT,01,01,02,Deviation Calibration Successfully Completed\*17<CR><LF> This sentence indicates a successful calibration and you can jump to step number 6.
  - b. \$IITXT,01,01,03,Deviation Calibration Failed To Complete\*43<CR><LF> This sentence indicates that the calibration failed (return to step number 1).
6. Turn the periodic transmissions back on by sending the following Maretron proprietary NMEA0183 sentence to the SSC200 - \$PMAREXE,SSC200,,FD,1,,,<CR><LF>
7. Proceed to Installation-Offset Correction

### **SSC200 NMEA 0183 Installation-Offset Correction**

Installation-offset correction can be performed by sending a Maretron proprietary NMEA 0183 sentence to the SSC200. The procedure is as follows:

1. Make sure the vessel is laying in flat water on a known heading,
2. Send the following Maretron proprietary NMEA 0183 sentence to the SSC200:  
`$PMAREXE,SSC200,,24,"known heading in tenths of degrees",,,<CR><LF>`  
Where "known heading in tenths of degrees" is expressed in 10<sup>th</sup> of degrees (i.e., 121.7° would be programmed as 1217)

Sending this Maretron proprietary NMEA 0183 sentence to the SSC200 causes the heading, roll, and pitch offsets to be written to permanent memory.



## Appendix B – NMEA 2000® Interfacing

### SSC200 NMEA 2000® Periodic Data Transmitted PGNs

#### **PGN 127250 – Vessel Heading**

The SSC200 uses this PGN to indicate the vessel's heading. The Heading Sensor Reading (field 2) includes deviation, therefore Deviation (field 2) always contains zero. Variation (field 4) is not provided by the SSC200, therefore this field always contains a value of 0x7FFF (data not available). Since the SSC200's core technology is based on magnetometers, the Heading Sensor Reference (field 5) is always set to magnetic.

- Field 1: SID – The sequence identifier field is used to tie related PGNs together. For example, the SSC200 will transmit identical SIDs for Vessel Heading (PGN 127250), Attitude (127257), and Rate of Turn (127251) to indicate that the readings are linked together (i.e., the data from each PGN was taken at the same time although they are reported at slightly different times).
- 2: Heading Sensor Reading – This field is used to report the vessel's heading and includes deviation assuming a deviation table has been successfully loaded through the magnetic deviation calibration process.
  - 3: Deviation – The deviation is included in field 2, therefore this field always reads as 0.
  - 4: Variation – The SSC200 does not use this field so the field is transmitted with the value 0x7FFF (data not available). See PGN 127258 for information regarding the SSC200 and its ability to transmit magnetic variation.
  - 5: Heading Sensor Reference – The SSC200 transmits a "1" in this field to indicate that the heading is referenced to magnetic North
  - 6: Reserved – This field is reserved by NMEA; therefore, the SSC200 sets all bits to a logic 1.

#### **PGN 127251 – Rate of Turn**

The SSC200 uses this PGN to indicate the vessel's rate of turn.

- Field 1: SID – The sequence identifier field is used to tie related PGNs together. For example, the SSC200 will transmit identical SIDs for Vessel Heading (PGN 127250), Attitude (127257), and Rate of Turn (127251) to indicate that the readings are linked together (i.e., the data from each PGN was taken at the same time although they are reported at slightly different times).
- 2: Rate of Turn – This field is used to report the vessel's rate of turn.
  - 3: Reserved – This field is reserved by NMEA; therefore, the SSC200 sets all bits to a logic 1.

#### **PGN 127257 – Attitude**

The SSC200 uses this PGN to indicate the vessel's attitude (pitch and roll). The Yaw (field 2) is not used, therefore this field always contains 0x7FFF (data not available).

- Field 1: SID – The sequence identifier field is used to tie related PGNs together. For example, the SSC200 will transmit identical SIDs for Vessel Heading (PGN 127250), Attitude (127257), and Rate of Turn (127251) to indicate that the readings are linked together (i.e., the data from each PGN was taken at the same time although they are reported at slightly different times).

- 2: Yaw – This field always contains a value of 0x7FFF (data not available).
- 3: Pitch – This field is used to report the vessel's pitch.
- 4: Roll – This field is used to report the vessel's roll.
- 5: Reserved – This field is reserved by NMEA; therefore, the SSC200 sets all bits to a logic 1.

### ***PGN 127258 – Magnetic Variation***

The SSC200 may or may not periodically transmit this PGN depending on whether or not it has been programmed with the local magnetic variation. Programming the magnetic variation (through a Maretron display product like the DSM200) will cause the SSC200 to transmit this PGN once per second. If the local magnetic variation is not known, then the variation can be disabled (again, through a display product like the DSM200) at which time the SSC200 will cease to transmit this PGN.

- Field 1: SID – The sequence identifier field is used to tie related PGNs together. For example, the SSC200 will transmit identical SIDs for Vessel Heading (PGN 127250), Attitude (127257), and Rate of Turn (127251) to indicate that the readings are linked together (i.e., the data from each PGN was taken at the same time although they are reported at slightly different times).
- 2: Variation Source – This field always contains a value of 0x00 (manual entry).
  - 3: Reserved – This field is reserved by NMEA; therefore, the SSC200 sets all bits to a logic 1.
  - 4: Age of Service – This field always contains a value of 0x7FFF (data not available).
  - 5: Variation – This field is used to report the local magnetic variation as entered by the user. Positive values are Easterly and negative values are Westerly.

***WARNING: Magnetic variation changes as your location on the earth changes and it should be adjusted with these changes. Neither the DSM200 nor the SSC200 will make these changes automatically; they are the responsibility of the user.***

## **SSC200 NMEA 2000® Non-Periodic Data Transmitted PGNs**

### ***PGN 126270 – Maretron Proprietary Slave Response – Deviation Calibration Status***

This indicates the status of the deviation calibration process.

- Field 1: Maretron Vendor ID and Industry Code (16 bits) – this field's value will be 0x9889
- 2: Product Code (16 bits) – this field's value will be 0x1B2, which is the NMEA 2000® product code for the SSC200.
  - 3: Software Code (16 bits) – this field's value will be 0x0001, which is the identifier for this version of the Maretron proprietary protocol
  - 4: Command (8 bits) – this field's value will be 0x50, which indicates that this response contains status for deviation calibration
  - 5: Status Code (8 bits) – this field will indicate the status of the calibration process with one of the values from the following table (see following table).

Status Code	Message Name	Description
01	Deviation Calibration Started	This message is transmitted at the beginning of the magnetic deviation calibration process.
02	Deviation Calibration Completed Successfully	This message is transmitted upon successful completion of the magnetic deviation calibration process (i.e., a new deviation table has been stored in permanent memory).
03	Deviation Calibration Failed to Complete	The SSC200 attempts to perform calibration 5 times before giving up and issuing this sentence. Each time the SSC200 encounters an error (see message identifiers 04, 05, and 06) it restarts the calibration process. Upon the 5 <sup>th</sup> error, the SSC200 exits the calibration routine and it must be restarted before it will once again try to perform deviation calibration.
04	Deviation Calibration Turning Too Fast	During calibration, the vessel must not turn to fast where the SSC200 is unable to reliably develop deviation data. If the SSC200 senses the vessel turning to quickly, it will issue this message and restart deviation calibration as long as it has not failed five times.
05	Deviation Calibration Turning Too Slow	During calibration, the vessel must not turn to slowly where the SSC200 is unable to reliably develop deviation data. If the SSC200 senses the vessel turning to slowly, it will issue this message and restart deviation calibration as long as it has not failed five times.
06	Deviation Calibration Invalid Movement	During calibration, the vessel must not jerk or reverse directions where the SSC200 is unable to reliably develop deviation data. If the SSC200 senses an invalid movement, it will issue this message and restart deviation calibration as long as it has not failed five times.

## **SSC200 NMEA 2000® Received PGNs**

### ***PGN 126208 – NMEA Command Group Function – Maretron Proprietary Reset***

This will initiate a reset and force the SSC200 to start the calibration process.

- Field 1: Complex Command Group Function Code (8 bits) – set this field's value to 0x01, which denotes a command PGN
- 2: Commanded PGN (24 bits) – set this field's value to 126720, which denotes the Maretron proprietary PGN
- 3: Priority Setting (4 bits) – set this field's value to 0x8, which indicates to leave priority settings unchanged
- 4: Reserved (4 bits) – set this field's value to 0xF, which is the value for a reserved field of this size
- 5: Number of Pairs of Commanded Parameters to Follow (8 bits) – set this field's value to 0x4, indicating that four parameters will follow
- 6: Number of First Commanded Parameter (8 bits) – set this field's value to 0x1
- 7: Maretron Vendor ID and Industry Code (16 bits) – set this field's value to 0x9889
- 8: Number of Second Commanded Parameter (8 bits) – set this field's value to 0x02
- 9: Product Code (16 bits) – set this field's value to 0x1B2, which is the NMEA 2000® product code for the SSC200.
- 10: Number of Third Commanded Parameter (8 bits) – set this field's value to 0x03
- 11: Software Code (16 bits) – set this field's value to 0x0001, which is the identifier for this version of the Maretron proprietary protocol

- 12: Maretron Command – set this field's value to 0xF0, which will initiate a reset and start the calibration process.

**PGN 126208 – NMEA Command Group Function – Maretron Proprietary Installation Offset.** This PGN performs the installation offset of the compass. It sets the roll and pitch outputs to zero at the compass' current orientation and sets the heading reading for the current orientation to the value given by the PGN (see page B3 for complete description of PGN 126270).

- Field 1: Complex Command Group Function Code (8 bits) – set this field's value to 0x01, which denotes a command PGN
- 2: Commanded PGN (24 bits) – set this field's value to 126720 decimal (0x1EF00 hexadecimal), which denotes the Maretron proprietary PGN
  - 3: Priority Setting (4 bits) – set this field's value to 0x8, which indicates to leave priority settings unchanged
  - 4: Reserved (4 bits) – set this field's value to 0xF, which is the value for a reserved field of this size
  - 5: Number of Pairs of Commanded Parameters to Follow (8 bits) – set this field's value to 0x4, indicating that four parameters will follow
  - 6: Number of First Commanded Parameter (8 bits) – set this field's value to 0x1
  - 7: Maretron Vendor ID and Industry Code (16 bits) – set this field to 0x9889, which is a combination of Maretron's vendor ID and the marine industry code
  - 8: Number of Second Commanded Parameter (8 bits) – set this field's value to 0x02
  - 9: Product Code (16 bits) – set this field's value to 0x1B2, which is the NMEA 2000® product code for the SSC200.
  - 10: Number of Third Commanded Parameter (8 bits) – set this field's value to 0x03
  - 11: Software Code (16 bits) – set this field's value to 0x0001, which is the identifier for this version of the Maretron proprietary protocol
  - 12: Maretron Command (8 bits) – set this field's value to 0x24, which will cause installation-offset calibration to be performed
  - 13: Heading Value (16 bits) – set this field's value to the current known heading in tenths of degrees (a value between 0 and 3599). For example, 121.7° would be programmed as 1217 decimal, or 0x4C1 hexadecimal.

**PGN 126208 – NMEA Request Group Function – Transmission Periodic Rate**

This PGN will enable or disable the periodic transmission of specific PGNs.

- Field 1: Complex Command Group Function Code (8 bits) – set this field's value to 0x00, which denotes a request PGN
- 2: Requested PGN (24 bits) – set this field's value to the corresponding PGN for which you wish to change the periodic rate.
  - 3: Transmission Interval (32 bits) – set this field's value to 0x0 to disable the periodic transmission of the PGN identified in field 2 above. Otherwise, program in the default periodic rate to restore periodic transmission of the PGN identified in field 2 above. The resolution of this field is 1 millisecond.
  - 4: Transmission Interval Offset (16 bits) – set this field's value to 0xFFFF; all other values will cause the request to be rejected.
  - 5: Number of Pairs of Commanded Parameters to Follow (8 bits) – set this field's value to 0x0.

## **SSC200 NMEA 2000® Initiated Deviation Calibration**

NMEA 2000® initiated deviation calibration is accomplished by turning the vessel through at least 3 complete circles after the SSC200 receives a Maretron proprietary NMEA 2000® PGN. The procedure is as follows:

1. Ensure that the compass has been properly installed per Section 2,
2. Warm up the compass by operating it for approximately 10 minutes,
3. Turn the vessel (either direction) such that you complete a full 360° turn in 2½ minutes or less (try not to go below 1 minute for a complete circle),
4. Send the following NMEA 2000® PGN to the SSC200 while continuing to turn the vessel:

***PGN 126208 – NMEA Command Group Function – Maretron Proprietary Reset.***

This will initiate a reset and force the SSC200 to start the calibration process (see page B3 for complete description of PGN 126208).

5. Continue turning the vessel through at least 3 circles until you see one of the following Maretron proprietary NMEA 2000® PGNs:
  - a. ***PGN 126270 – Maretron Proprietary Slave Response – Deviation Calibration Successfully Completed.*** This indicates successful completion of the deviation calibration process (see page B2 for complete description of PGN 126270).
  - b. ***PGN 126270 – Maretron Proprietary Slave Response – Deviation Calibration Failed to Complete.*** This indicates a failure of the deviation calibration process (see page B2 for complete description of PGN 126270).

## **SSC200 NMEA 2000® Installation-Offset Correction**

Installation-offset correction can be performed by sending a Maretron proprietary NMEA 2000® PGN to the SSC200. The procedure is as follows:

1. Make sure the vessel is laying in flat water on a known heading,
2. Send the following NMEA 2000® PGN to the SSC200:
  - a. ***PGN 126208 – NMEA Command Group Function – Maretron Proprietary Installation Offset.*** This PGN performs the installation offset of the compass. It sets the roll and pitch outputs to zero at the compass' current orientation and sets the heading reading for the current orientation to the value given by the PGN (see page B2 for a complete description of PGN 126270).



## Appendix C – Connecting to a PC Via NMEA 0183

In order to perform configuration of the SSC200 over the NMEA 0183 interface, it is preferable that the connection be made by a RS-232 to RS-422 level converter. In the case that a level converter is not available, the following method can be attempted:

1. Connect the SSC200 to the PC's serial port. Please note that the SSC200 uses RS-422 signal levels, while PC serial ports operate with RS-232 signal levels. If you do not have a RS-232 to RS-422 level converter, some people have reported success connecting directly to a RS-232 serial port using the following connections:
  - a. Connect TXB (brown) and RXB (white) together and to the System Ground pin (GND, pin 5) of the RS-232 port.
  - b. Connect TXA (gray) to the Receive Data pin (RXD, pin 2) of the RS-232 port.
  - c. Connect RXA (blue) to the Transmit Data pin (TXD, pin 3) of the RS-232 port.

Ensure that the NMEA 0183 signals from the SSC200 are connected to nothing else besides the computer's RS-232 port to avoid ground loops. While some people have had success with this method, Maretron cannot guarantee that such a connection will work with every computer and highly recommends the use of a level converter.

2. Connect power to the compass:
  - a. Connect 9-16 VDC to V+ (red).
  - b. Connect system ground to V- (black).
3. Start Hyperterm and connect it to the port to which the SSC200 is connected (4800 or 38400 bps, depending on the baudrate the compass is set to, 8 data bits, no parity, 1 stop bit). You should now see compass data in the form of NMEA0183 sentences on the Hyperterm screen.
4. Type "shell".  
The NMEA0183 sentences will stop and a "cmd>" prompt will appear.





## Appendix D – Configuring the SSC200 to Transmit True Heading Data

The SSC200 is factory configured to transmit magnetic heading data on the NMEA0183 interface. Some NMEA 0183 applications require true heading data. This application note describes how to configure the SSC200 to transmit true heading data

### Prerequisites:

- The SSC200 compass must have firmware revision 1.7 or greater.
- The SSC200 compass must either transmit the default HDG sentence or be configured to transmit the HDT sentence (see Application Note #1, “Configuring the SSC200 to Transmit the HDT Sentence for Satellite Antennas and Radars”).

### Instructions:

There are two choices for a magnetic variation source for the SSC200, GPS (preferred) or manual.

#### GPS Variation

In order to use a GPS to enable the SSC200 compass to transmit true heading data, the GPS antenna must transmit magnetic variation data. Not all GPS antennas transmit magnetic variation data. Please consult the GPS antenna user’s manual for details.

1. Ensure that the GPS antenna is configured to transmit either the RMC or VTG sentence. Either sentence should work equally well.
2. Connect the NMEA 0183 output of the GPS antenna to the NMEA 0183 input of the SSC200. Please note the following cable connections on the SSC200:

<u>GPS Connection</u>	<u>SSC200 Connection</u>
TXA (TX+)	Blue Wire, RXA (RX+)
TXB (TX-)	White wire, RXB (RX-)

3. The SSC200 should now be transmitting true heading data. Examine the NMEA 0183 sentences coming from the SSC200 or check the heading indication on the system connected to the NMEA 0183 output of the SSC200 for true heading data.
4. If no true heading data is observed at this point, try
  - d. switching the wires on the GPS->SSC200 connection, as not all manufacturers are consistent in their labeling of the NMEA 0183 wires
  - e. ensuring the SSC200 is configured to transmit either HDG or HDT
  - f. ensuring the GPS antenna is transmitting Magnetic Variation Data. The sentences should look one of the sentences below, where the lowercase letter placeholders are replaced with numerical values.

```
$GPRMC, hmmm.ss , A , llll.ll , a , yyyyy.yy , a , x.x , x.x , xxxxxx , x.x , a , a*hh
```

The two underlined fields contain the magnetic variation data and must be present in order for this sentence to be used for magnetic variation.

```
$GPVTG, x.x , T , x.x , M , x.x , N , x.x , K , a*hh
```

The two underlined fields contain the true and magnetic course over ground data. Both values must be present in order for this sentence to be used for magnetic variation.

#### Manual Variation

1. Connect the SSC200 to the PC's serial port and obtain the “cmd>” prompt per the instructions in Appendix C.
2. To program the SSC200 with a manually magnetic variation value, type the following sentence

## ***SSC200 User's Manual***

---

```
$PMAREXE,SSC200,,5D,0,<variation>, ,
```

Where *<variation>* is the magnetic variation in units of degrees and resolution in tenth of degrees – positive values represent easterly variation, and negative values represent westerly variation. For example, to program the SSC200 with 18.0° easterly magnetic variation, as might be seen in Seattle, WA, USA, type the sentence:

```
$PMAREXE,SSC200,,5D,0,18.0, ,
```

To program the SSC200 with 5.5° westerly magnetic variation, as might be seen on the east coast of Florida, USA, type the sentence:

```
$PMAREXE,SSC200,,5D,0,-5.5, ,
```

5. The SSC200 should now be transmitting true heading data. Examine the NMEA 0183 sentences coming from the SSC200 or check the heading indication on the system connected to the NMEA 0183 output of the SSC200 for true heading data.

## Appendix E - Configuring the SSC200 to Transmit the HDT Sentence for Satellite Antennas and Radars

The SSC200 is factory configured to transmit the HDG sentence 10 times per second. However, certain satellite antennas and radars need the HDT sentence. This application note explains how to change the transmitted sentence from to HDT.

### Prerequisites:

- The SSC200 compass must have firmware revision 1.7 or greater.
- The SSC200 compass must have a GPS source for magnetic variation information or must be manually programmed with the local magnetic variation (Please see Maretron Application Note #2, "Configuring the SSC200 to transmit True Heading Data")

### Instructions:

1. Connect the SSC200 to the PC's serial port and obtain the "cmd>" prompt per the instructions in Appendix C.
2. To disable transmission of the HDG sentence, type the following sentence:

```
$PMARSETPX,SSC200,,00,0
```

3. To enable transmission of the HDT sentence at 100 ms intervals (10 times per second), type the sentence:

```
$PMARSETPX,SSC200,,02,100
```

\*Note: For compasses with firmware revision 1.8 or greater, a NMEA 0183 checksum is optional. For compasses with earlier firmware revisions, a correct NMEA 0183 checksum is required.

4. Type "exit" or simply power the SSC200 off and then on again. You should now observe HDT sentences being transmitted.