

# USB100 NMEA 2000® / NMEA 0183 Gateway

## User's Manual

Revision 1.4

Copyright © 2009 Maretron, LLP All Rights Reserved

Maretron, LLP  
9014 N 23rd Av. #10  
Phoenix, AZ 85021  
<http://www.maretron.com>

Maretron Manual Part #: M000601

## Revision History

Revision	Description
1.0	Original document.
1.1	Updated to correspond to FW Version 1.5 Added description for configuration by DSM200
1.2	Added description of translations from NMEA 0183 sentences to NMEA 2000® PGNs (2.6.3, Appendix B)
1.3	Updated to correspond to FW Version 1.7.1
1.4	Updated mechanical drawings and measurements in technical specifications to match new (black) product enclosure Added description of translations of the following PGN's: 127488, 127489, 127505, 128259, 130311, 130576 Added new PGN's and Translated Data items to technical specifications Updated to correspond to FW Version 1.8.3

## Table of Contents

1	Introduction .....	1
1.1	Firmware Revision .....	1
1.2	USB100 Features .....	1
1.3	Quick Install .....	1
2	Installation .....	2
2.1	Unpacking the Box .....	2
2.2	Software Installation .....	2
2.3	Choosing a Mounting Location .....	5
2.4	Mounting the USB100 .....	6
2.5	Connecting the USB100 .....	6
2.5.1	Checking Connections .....	7
2.6	Configuring the USB100 .....	7
2.6.1	NMEA 2000® to NMEA 0183 Sentence Translations .....	7
2.6.1.1	GWUtilities Configuration Program .....	8
2.6.1.1.1	What is GWUtilities? .....	8
2.6.1.1.2	How to Use GWUtilities .....	9
2.6.1.1.3	GWUtilities Status Messages .....	10
2.6.2	NMEA 2000® Device Selection .....	10
2.6.3	NMEA 0183 Sentences to NMEA 2000® Translations .....	10
3	Maintenance .....	11
4	Troubleshooting .....	11
5	Technical Specifications .....	12
6	Technical Support .....	14
7	Installation Template .....	15
8	Maretron (2 Year) Limited Warranty .....	16

## Table of Figures

Figure 1	– Mounting the USB100 .....	6
Figure 2	– USB100 Interface Connector .....	6
Figure 3	– NMEA 2000® Connector Face Views .....	7
Figure 4	– Mounting Surface Template .....	15

## Table of Tables

Table 1	– NMEA 2000® to NMEA 0183 Sentence Translations .....	8
Table 2	– NMEA 0183 to NMEA 2000® Translations .....	11

## Table of Appendices

Appendix A	– NMEA 2000® to NMEA 0183 Translations .....	A1
Appendix B	– NMEA 0183 to NMEA 2000® Translations .....	B1

This Page Intentionally Left Blank

## 1 Introduction

Congratulations on your purchase of the Maretron USB100 NMEA 2000® / NMEA 0183 Gateway. Maretron has designed and built your gateway to the highest standards for years of dependable and accurate service.

Maretron's USB100 is a gateway for bridging USB equipment using NMEA 0183 sentences – such as an on-board computer running navigational software – with an NMEA 2000® network. The gateway automatically converts incoming NMEA 2000® messages (referred to as PGNs) to NMEA 0183 sentences so you can continue benefiting from navigational and charting software that you already own while enjoying the many benefits of networked NMEA 2000® instruments. The USB100 also converts navigational NMEA 0183 sentences (RMB, BOD) originating from charting systems into corresponding NMEA 2000® navigation PGNs so you can display rolling road information on NMEA 2000® display products such as the Maretron DSM200.

The Maretron USB100 is designed to operate within the harsh demands of the marine environment. However, no piece of marine electronic equipment can function properly unless installed, configured, and maintained in the correct manner. Please read carefully and follow these instructions for installation, configuration, and usage of the Maretron USB100 in order to ensure optimal performance.

### 1.1 Firmware Revision

This manual corresponds to USB100 firmware revision 1.8.3.

### 1.2 USB100 Features

The Maretron USB100 has the following features.

- NMEA 2000® and USB 1.1 Interfaces
- Waterproof NMEA 2000® and USB Connectors
- Sealed Waterproof Enclosure
- Translates More than 20 NMEA 2000® PGNs to Equivalent NMEA 0183 Sentences
- Translates NMEA 0183 Sentences to Corresponding NMEA 2000® PGNs
- USB Opto-Isolated from NMEA 2000® Eliminating Potential Ground Loops
- Obtains Power Directly from USB and NMEA 2000® Ports

### 1.3 Quick Install

Installing the Maretron USB100 gateway involves the following six steps. Please refer to the individual sections for additional details.

1. Unpack the Box (Section 2.1)
2. Install Software on PC (Section 2.2)
3. Choose a Mounting Location (Section 2.3)
4. Mount the USB100 (Section 2.4)
5. Connect the USB100 (Section 2.5)
6. Configure the USB100 - Optional, only required for specialized configurations (Section 2.6)

## 2 Installation

### 2.1 Unpacking the Box

When unpacking the box containing the Maretron USB100, you should find the following items:

- 1 – USB100 NMEA 2000® to NMEA 0183 Gateway
- 4 – Mounting Screws
- 1 – USB100 Driver / Support Software CD
- 1 – USB100 User's Manual
- 1 – Warranty Registration Card

If any of these items are missing or damaged, please contact Maretron.

### 2.2 Software Installation

In order to use the USB100 with a PC running Microsoft Windows 2000 or Microsoft Windows XP, you must first install the software on the provided "USB100 Driver / Support Software CD". To begin, insert the CD into your CD-ROM drive. If you have AutoPlay enabled for the CD-ROM drive, the installation program will start automatically; otherwise, open the CD-ROM drive in Windows Explorer and execute the "setup.exe" file in the root folder of the CD-ROM drive.

Once started, the *GWUtilities* setup program will display the following screen. Click the button marked "Next" to continue the installation of the software.



The next screen gives you the opportunity to specify the installation directory for the *GWUtilities* program. The default selection should be acceptable for most installations. If desired, select a different installation directory. Finally, click the button marked “Next” to continue the installation process.

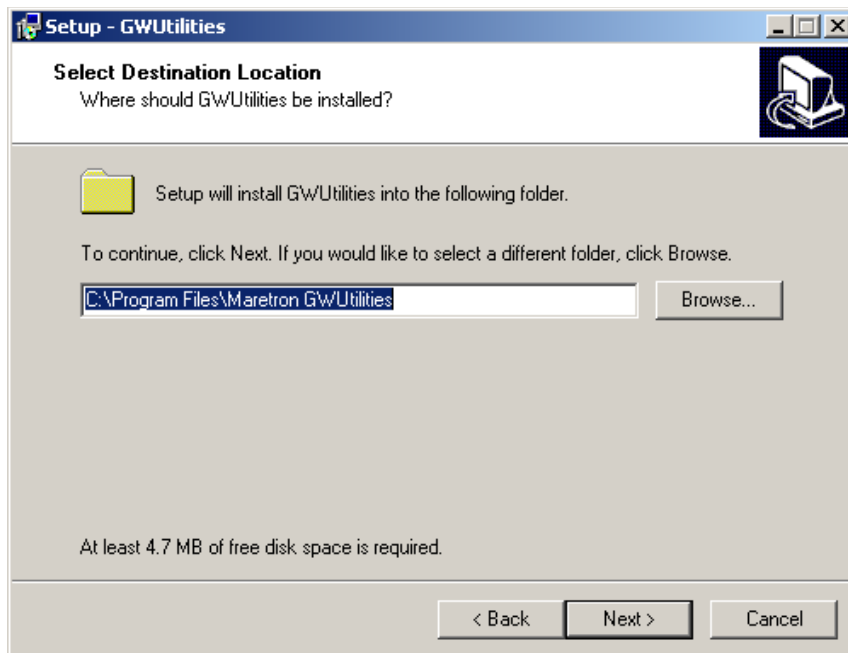

The next screen allows you the opportunity to change the name of the Start Menu folder into which program shortcuts are installed. If desired, specify a new Start Menu folder name and click the button marked “Next” to continue; otherwise, simply click the button marked “Next” to accept the default choice and continue the software installation.

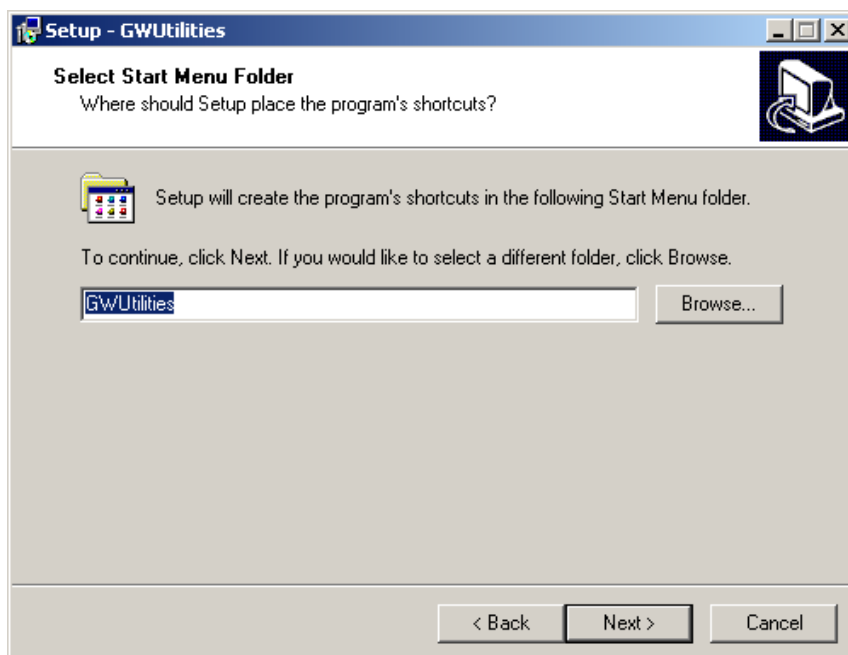

## USB100 User's Manual

---

The following screen allows you the opportunity to create an icon for the *GWUtilities* program on your desktop or in the Quick Launch bar. If you wish, select one or both of these options. Then, click the button marked "Next" to continue.

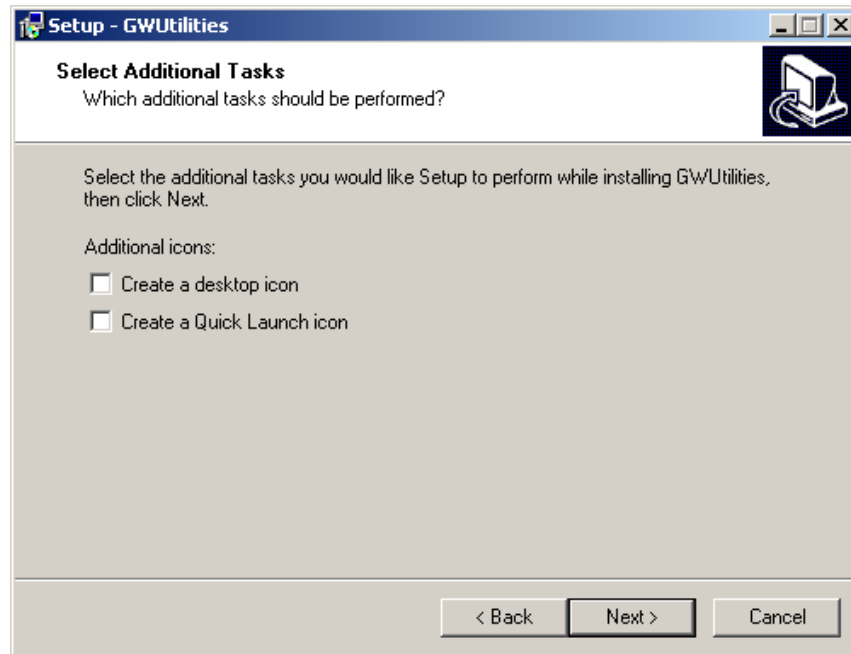

Now, a screen appears allowing you to confirm the installation options you have selected and initiate the installation process. If you wish to change any of these options, click the button marked "Back". If you are satisfied with the options you have selected, click the button marked "Install" to begin the installation process.

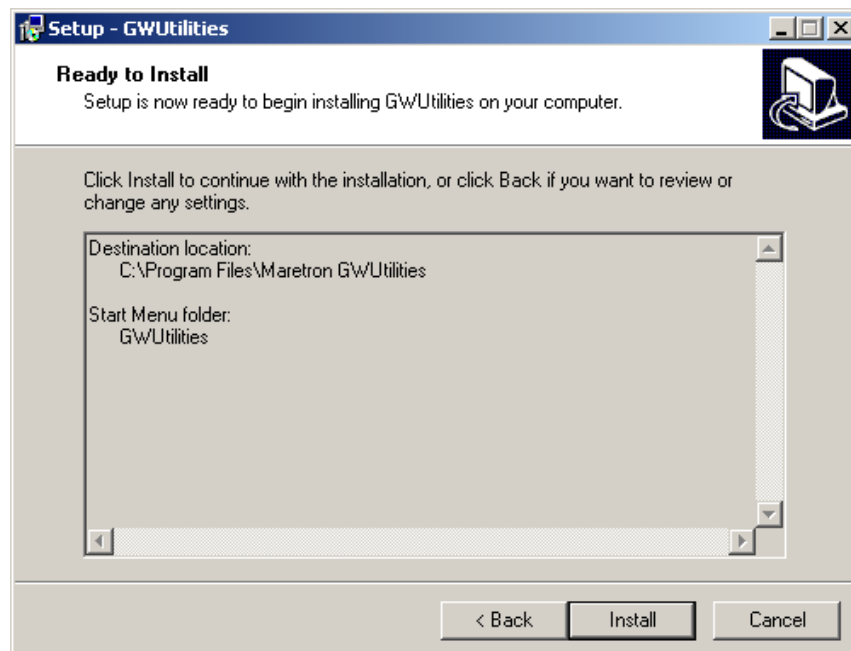

You will now see status screens that indicate the progress of the installation. After the installation is complete, a screen appears which indicates successful completion of the installation. Click the “Finish” button to complete the installation process.

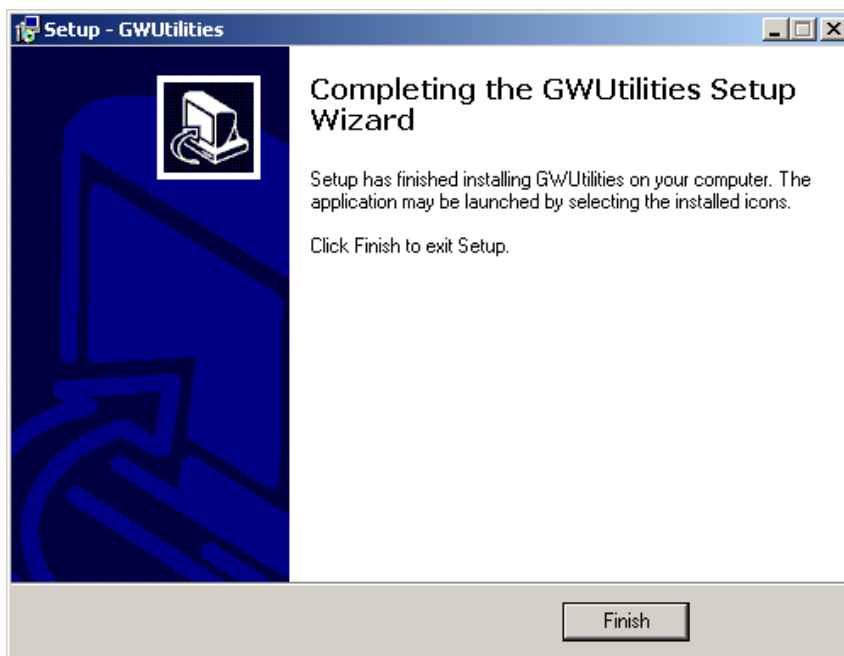

## 2.3 Choosing a Mounting Location

The USB100 can be mounted in any location and in any orientation; however, the mounting location should be close to the location of the computer. The maximum legal length of a USB cable is 5 meters (16' 5") so the USB100 should be mounted within this distance of the computer. If the distance between the USB100 and the computer is greater than 5 meters, a USB hub or USB extender must be used.

## 2.4 Mounting the USB100

Attach the USB100 securely to the vessel using the included brass mounting screws or other fasteners as shown in Figure 1 below.

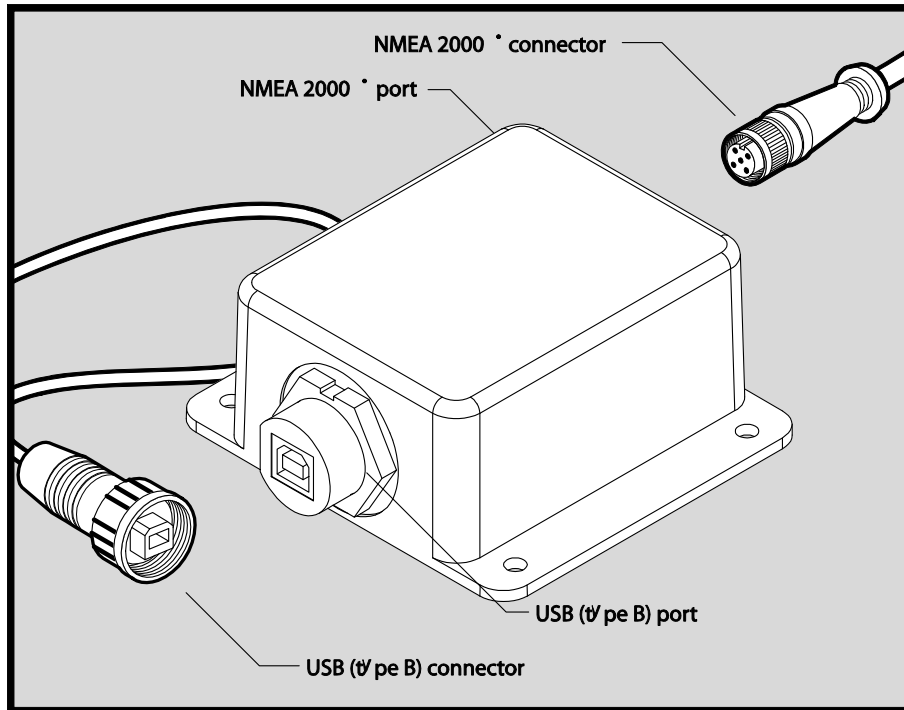

**Figure 1 – Mounting the USB100**

## 2.5 Connecting the USB100

The Maretron USB100 provides a connection to an NMEA 2000® interface through a connector that can be found on the end of the device (see Figure 2).

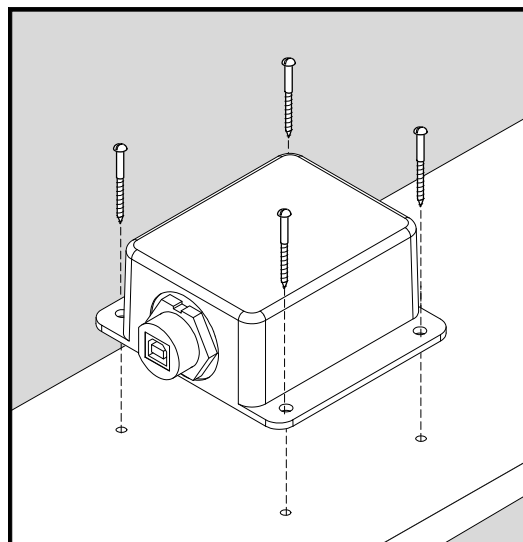

**Figure 2 – USB100 Interface Connector**

The NMEA 2000® connector is a five pin male connector (see Figure 3). You connect the USB100 to an NMEA 2000® network using a Maretron NMEA 2000® cable (or compatible cable) by connecting the female end of the cable to the USB100 (note the key on the male connector and keyway on the female connector). Be sure the cable is connected securely and that the collar on the cable connector is tightened firmly. Connect the other end of the cable (male) to the NMEA 2000® network in the same manner. The USB100 is designed such that you can plug or unplug it from an NMEA 2000® network while the power to the network is connected or disconnected. Please follow recommended practices for installing NMEA 2000® network products.

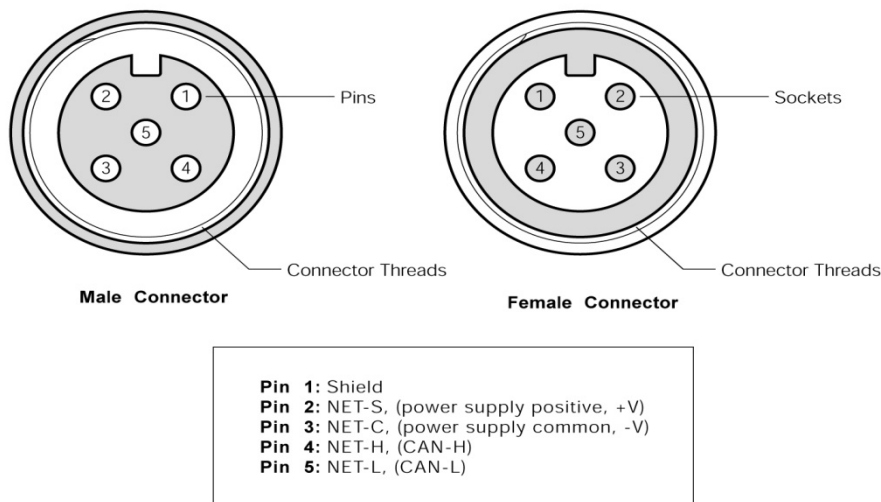

**Figure 3 – NMEA 2000® Connector Face Views**

## 2.5.1 Checking Connections

Once the NMEA 2000® and USB connections to the Maretron USB100 have been completed, check to see that information is being properly transmitted by observing that your computer software is receiving NMEA 0183 sentences via the USB port. Refer to Section 4, “Troubleshooting”, if no information appears.

## 2.6 Configuring the USB100

As shipped from the factory, the USB100 does not require any special configuration and will work for most applications. However, there are two configurable items in the USB100 which includes: 1) NMEA 2000® to NMEA 0183 sentence translations and 2) NMEA 2000® device selection.

### 2.6.1 NMEA 2000® to NMEA 0183 Sentence Translations

The following table shows the NMEA 2000® PGNs received from an NMEA 2000® network and the corresponding translations to NMEA 0183 sentences for use by the PC.

Received NMEA 2000 PGN		Transmitted NMEA 0183 Sentence		Transmit Default
Number	Description	Acronym	Description	
126992	System Time	ZDA	Time & Date	On
127245	Rudder	RSA	Rudder Sensor Angle	On
127250	Vessel Heading	HDG/HDT	Heading, Dev. & Var. / Heading, True	On
127251	Rate of Turn	ROT	Rate of Turn	On
127257	Attitude	PMAROUT	Proprietary Maretron Sentence	On
127488	Engine Parameters, Rapid Update	RPM/ PMAREPR	Revolutions/ Proprietary Maretron Sentence	On
127489	Engine Parameters, Dynamic	PMAREPD	Proprietary Maretron Sentence	On
127505	Fluid Level	XDR	Transducer Measurement	On
127508	Battery Status	XDR	Transducer Measurement	On
128259	Speed	VBW/VHW	Dual Ground/Water Speed / Water Speed and Heading	On
128267	Water Depth	DPT	Depth	On
128275	Distance Log	VLW	Dual Ground/Water Distance	On
129025	Position, Rapid Update	GLL	Geographic Position – Latitude/Longitude	Off
129026	COG & SOG, Rapid Update	VTG	Course Over Ground and Ground Speed	On
129029	GNSS Position Data	GGA/GNS	GPS Fix Data / GNSS Fix Data	On
129029	GNSS Position Data	GLL	Geographic Position – Latitude/Longitude	On
129033	Time & Date	ZDA	Time & Date	On
129539	GNSS DOPs	GSA	GNSS DOP and Active Satellites	Off
129540	GNSS Sats in View	GSV	GNSS Satellites in View	On
129540	GNSS Sats in View	GSA	GNSS DOP and Active Satellites	On
130306	Wind Data	MWD/MWV	Wind Dir. & Speed / Wind Speed & Angle	On
130310	Environmental Parameters	MTW	Water Temperature	On
130310	Environmental Parameters	XDR	Transducer Measurement	On
130311	Environmental Parameters	MTW	Water Temperature	On
130311	Environmental Parameters	XDR	Transducer Measurement	On
130576	Small Craft Status	XDR	Transducer Measurement	On

**Table 1 – NMEA 2000® to NMEA 0183 Sentence Translations**

The easiest way to change or configure these translations is by the included *GWUtilities* program whose use is described in Section 2.6.1.1 below.

## 2.6.1.1 GWUtilities Configuration Program

### 2.6.1.1.1 What is GWUtilities?

*GWUtilities* is a program that allows a user to configure Maretron gateway products. Normally, the translations programmed into the gateway at the factory should be satisfactory, but a particular application may require that some of the normally enabled translations be disabled. In addition, gateway products contain additional translations that are not enabled at the factory and may need to be enabled for use with particular software.

## 2.6.1.1.2 How to Use GWUtilities

Below is an annotated screenshot of the main *GWUtilities* program window:

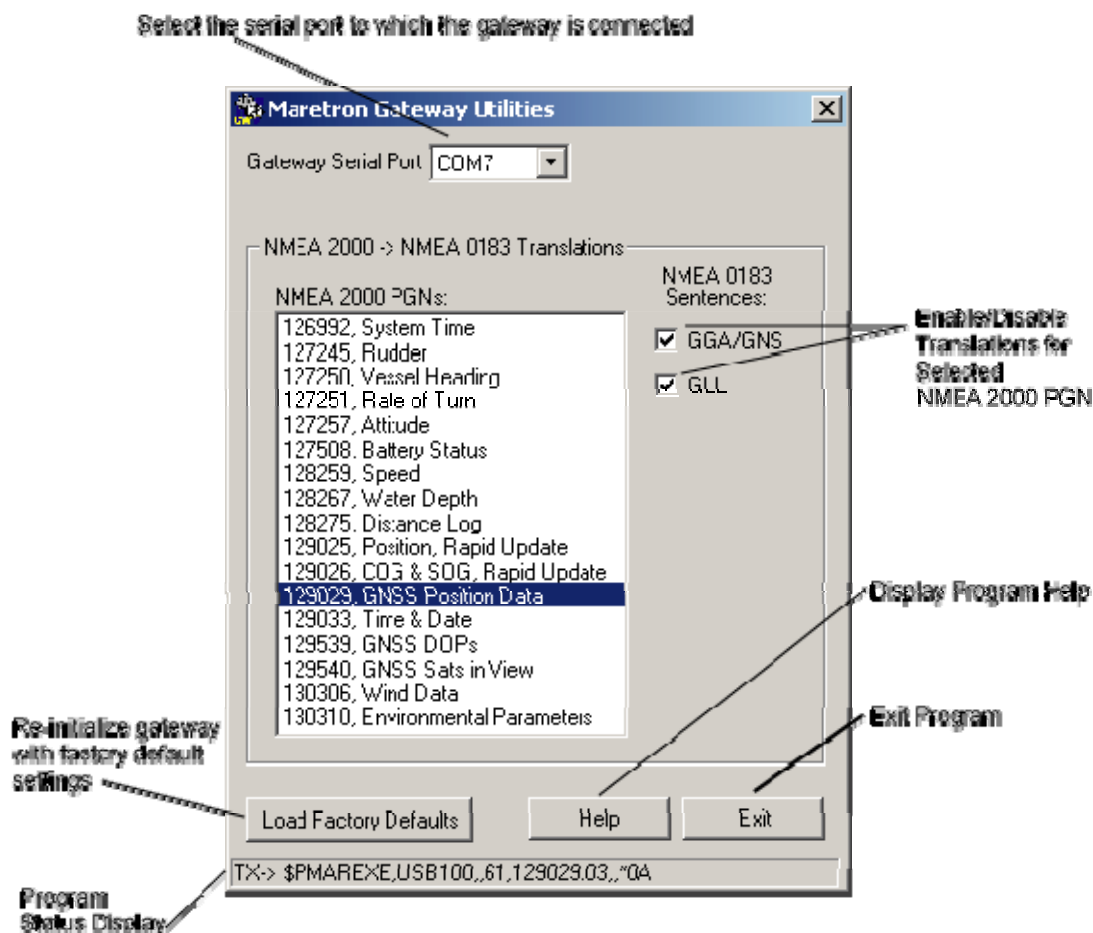

To use the program, perform the following steps:

1. Start the program.
2. Select the serial port to which the gateway is connected with the "Gateway Serial Port" selector. For USB connected gateways, you can determine the port to which the gateway is connected by opening the "Device Manager" and opening "Ports (COM & LPT)" and observing the ports labeled "Maretron NMEA 2000 USB Gateway".
3. Select a NMEA 2000® PGN in the "NMEA 2000® PGNs" listbox.
4. A list of checkboxes representing possible NMEA 0183 translations from the selected NMEA 2000® PGN will appear on the right hand side of the window. Sentence types with check boxes selected will be generated when the selected NMEA 2000® PGN is received. Sentence types with check boxes deselected will not be generated.
5. Repeat steps 3 and 4 until desired settings have been chosen. The gateway's settings are updated in real time; therefore, there is no need to explicitly "save" the settings to the gateway.
6. When you are finished, click the "Exit" button to exit the program.

If, at any time, you wish to restore the gateway to its factory configuration, click the "Load Factory Defaults" button.

### **2.6.1.1.3 GWUtilities Status Messages**

The *GWUtilities* program produces a variety of status messages on the bottom line of the program window. Following is a list of status messages and suggested actions, if any.

#### **No response received from gateway**

The gateway has not responded to a command sent to it by *GWUtilities*.

Suggestions:

- Check that the correct port has been assigned in the *Gateway Serial Port* listbox
- Check that the gateway has been supplied with power
- Check that the cable connection between the gateway and the PC is secure

#### **Failed to open serial port *portname***

*GWUtilities* was not able to open a connection to the serial port *portname*.

Suggestions:

- Check that the correct port has been assigned in the *Gateway Serial Port* listbox
- Check that any required drivers for the gateway have been installed correctly. You can do this by opening the Device Manager, opening "Ports (COM & LPT)", and selecting "Properties..." for the desired port and verifying that the port is operating correctly.

### **2.6.2 NMEA 2000® Device Selection**

Normally, the USB100 translates messages from all devices on the NMEA 2000® network. However, in some cases you may have multiple devices on the NMEA 2000® network; for instance, two GPS receivers or two depth transducers. When you have multiple devices of the same type on the NMEA 2000® network, you should configure the USB100 to translate PGN's from only one of those devices. The easiest way to configure these translations is with an attached Maretron DSM200 Multi-function Graphic Display unit. Please refer to the *DSM200 User's Manual* for details on how to configure device selection on a USB100 or copy device selection settings from a DSM200 to a USB100.

### **2.6.3 NMEA 0183 Sentences to NMEA 2000® Translations**

The USB100 is capable of receiving certain NMEA 0183 sentences from charting software running on a PC and converting the sentences to NMEA 2000® PGNs for subsequent display by NMEA 2000® devices. For example, when a PC charting system is in the process of navigating to a waypoint, it is capable of transmitting certain navigational sentences such that external equipment can display "rolling road" information. The following table shows the NMEA 0183 sentences received from PC charting systems and the corresponding translations to NMEA 2000® PGNs. Refer to Appendix B for specific details regarding translations.

Acronym	Received NMEA 0183 Sentence		Transmitted NMEA 2000® PGNs	
	Description	Number	Description	
RMB/BOD	Recommended Minimum Navigational Info / Bearing Origin to Destination	129284	Navigation Data	
RMB	Recommended Minimum Navigational Info	129283	Cross Track Error	
RMB	Recommended Minimum Navigational Info	129285	Navigation - Route / WP Data	

**Table 2 – NMEA 0183 to NMEA 2000® Translations**

## 3 Maintenance

Regular maintenance is important to ensure continued proper operation of the Maretron USB100. Perform the following tasks periodically:

- Clean the unit with a soft cloth. Do not use chemical cleaners as they may remove paint or markings or may corrode the USB100 enclosure or seals.
- Ensure that the unit is mounted securely and cannot be moved relative to the mounting surface. If the unit is loose, tighten the mounting screws.
- Check the security of the cable connected to the NMEA 2000® and USB interfaces and tighten if necessary.

## 4 Troubleshooting

If you notice unexpected operation of the Maretron USB100, follow the troubleshooting procedures in this section to remedy simple problems.

Symptom	Troubleshooting Procedure
No data output on USB interface	<p>Check the connections to the NMEA 2000 and USB connectors and tighten if necessary</p> <p>Ensure that power is supplied to the connected NMEA 2000 cable</p> <p>Ensure that the correct serial port is selected by the software expecting NMEA 0183 format data. Open the Device Manager and ensure that the selected port is labeled “Maretron NMEA 2000 USB Gateway” rather than “Standard COM port”.</p>

If these steps do not solve your problem, please contact Maretron Technical Support (refer to Section 6 for contact information).

*Warning: There are no user-serviceable components inside the Maretron USB100. Opening the USB100 will expose the sensitive electronic components to adverse environmental conditions that may render the unit inoperative. Please do not open the USB100, as this will automatically void the warranty. If service is required, please return the unit to an authorized Maretron service location.*

## 5 Technical Specifications

As Maretron is constantly improving its products, all specifications are subject to change without notice. Maretron products are designed to be accurate and reliable; however, they should be used only as aids to navigation and not as a replacement for traditional navigation aids and techniques.

### Specifications

Parameter	Value	Comment
NMEA 2000® Connector	DeviceNet Micro-C	Industry Standard Waterproof
NMEA 2000® / USB Isolation	Opto-Isolated	No Electrical Connection Across Bridge
USB Standard	USB 1.1	
USB Connector	USB Type B	Industry Standard Waterproof
USB Supported Signals	D+, D-, +5V, GND	Bi-directional Gateway
USB Auxiliary Power	+5 Volts < 50 mA	
USB Baud Rate	Up to 12 Mb/s	Full Speed USB Data Rate
USB Interface Modes	NMEA 0183	With Maretron-Supplied Windows® Drivers
	Native NMEA 2000®	With Maretron-Supplied API

### Certifications

Parameter	Comment
NMEA 2000® Standard	Level A
Maritime Navigation and Radiocommunication Equipment & Systems	IEC 61162-3
Maritime Navigation and Radiocommunication Equipment & Systems	IEC 60945
FCC and CE Mark	Electromagnetic Compatibility

### Translated Data Types (NMEA 2000® to NMEA 0183) – See Appendix A for Details

Description	Data Types
Battery Monitor	Voltage, Current, Temperature
Compass	Vessel Heading, Attitude, Rate of Turn
Depth	Water Depth, Transducer Offset
Engine	Standard Sentences: RPM. Proprietary Sentences: Boost Pressure, Tilt/Trim, Oil Pressure, Oil Temperature, Coolant Temperature, Alternator Potential, Fuel Rate, Total Engine Hours, Coolant Pressure, Fuel Pressure
Environment	Temperature, Humidity, Atmospheric Pressure
GPS	COG, SOG, DOP, Position, Satellites, Time, Date
Rudder Indicator	Rudder Position
Speed	Distance Log, Speed
Tanks	Fluid Level
Trim Tabs	Position
Weather Station	Water Temperature
Wind	Wind Direction and Speed

## NMEA 2000® Parameter Group Numbers (PGNs)

Description	PGN #	PGN Name	Default Rate	
Response to Requested PGNs	126464	PGN List (Transmit and Receive)	N/A	
	126996	Product Information	N/A	
	126998	Configuration Information	N/A	
Protocol PGNs	059392	ISO Acknowledge	N/A	
	059904	ISO Request	N/A	
	060416	ISO Transport Protocol, Connection Management	N/A	
	060160	ISO Transport Protocol, Data Transfer	N/A	
	060928	ISO Address Claim	N/A	
	065240	ISO Address Command	N/A	
	126206	NMEA	N/A	
Received PGNs	126992	System Time	N/A	
	127245	Rudder	N/A	
	127250	Vessel Heading	N/A	
	127251	Rate of Turn	N/A	
	127257	Attitude	N/A	
	127488	Engine Parameters, Rapid Update	N/A	
	127489	Engine Parameters, Dynamic	N/A	
	127505	Fluid Level	N/A	
	127508	Battery Status	N/A	
	128259	Speed	N/A	
	128267	Water Depth	N/A	
	128275	Distance Log	N/A	
	129025	Position, Rapid Update	N/A	
	129026	COG & SOG, Rapid Update	N/A	
	129029	GNSS Position Data	N/A	
	129033	Time & Date	N/A	
	129539	GNSS DOPs	N/A	
	129540	GNSS Sats In View	N/A	
	130306	Wind Data	N/A	
	130310	Environmental Parameters	N/A	
	130311	Environmental Parameters	N/A	
	130576	Small Craft Status	N/A	
	Transmitted PGNs	129283	Cross Track Error	N/A
		129284	Navigation Data	N/A
129285		Navigation – Route/WP Information	N/A	
Maretron Proprietary PGN's	126720	Configuration	N/A	

# USB100 User's Manual

---

## Electrical

Parameter	Value	Comment
Operating Voltage	9 to 16 Volts	DC Voltage
Power Consumption	<150mA	Average Current Drain
Load Equivalence Number (LEN)	3	NMEA 2000® Spec. (1LEN = 50 mA)
Reverse Battery Protection	Yes	Indefinitely
Load Dump Protection	Yes	Energy Rated per SAE J1113

## Mechanical

Parameter	Value	Comment
Size	3.11" x 3.46" x 1.38" (79mm x 88mm x 35mm)	Including Flanges for Mounting
Weight	8 oz. (227 g)	

## Environmental

Parameter	Value
IEC 60945 Classification	Exposed
Degree of Protection	IP67
Operating Temperature	-25°C to 55°C
Storage Temperature	-40°C to 70°C
Relative Humidity	93%RH @40° per IEC60945-8.2
Vibration	2-13.2Hz @ ±1mm, 13.2-100Hz @ 7m/s <sup>2</sup> per IEC 60945-8.7
Rain and Spray	12.5mm Nozzle @ 100liters/min from 3m for 30min per IEC 60945-8.8
Solar Radiation	Ultraviolet B, A, Visible, and Infrared per IEC 60945-8.10
Corrosion (Salt Mist)	4 times 7days @ 40°C, 95%RH after 2 hour Salt Spray Per IEC 60945-8.12
Electromagnet Emission	Conducted and Radiated Emission per IEC 60945-9
Electromagnetic Immunity	Conducted, Radiated, Supply, and ESD per IEC 60945-10
Safety Precautions	Dangerous Voltage, Electromagnetic Radio Frequency per IEC 60945-12

## 6 Technical Support

If you require technical support for Maretron products, you can reach us in any of the following ways:

Telephone: 1-866-550-9100  
Fax: 1-602-861-1777  
E-mail: [support@maretron.com](mailto:support@maretron.com)  
World Wide Web: <http://www.maretron.com>  
Mail: Maretron, LLP  
Attn: Technical Support  
9014 N. 23rd Ave Suite 10  
Phoenix, AZ 85021 USA

## 7 Installation Template

Please check the dimensions before using the following diagram as a template for drilling the mounting holes because the printing process may have distorted the dimensions.

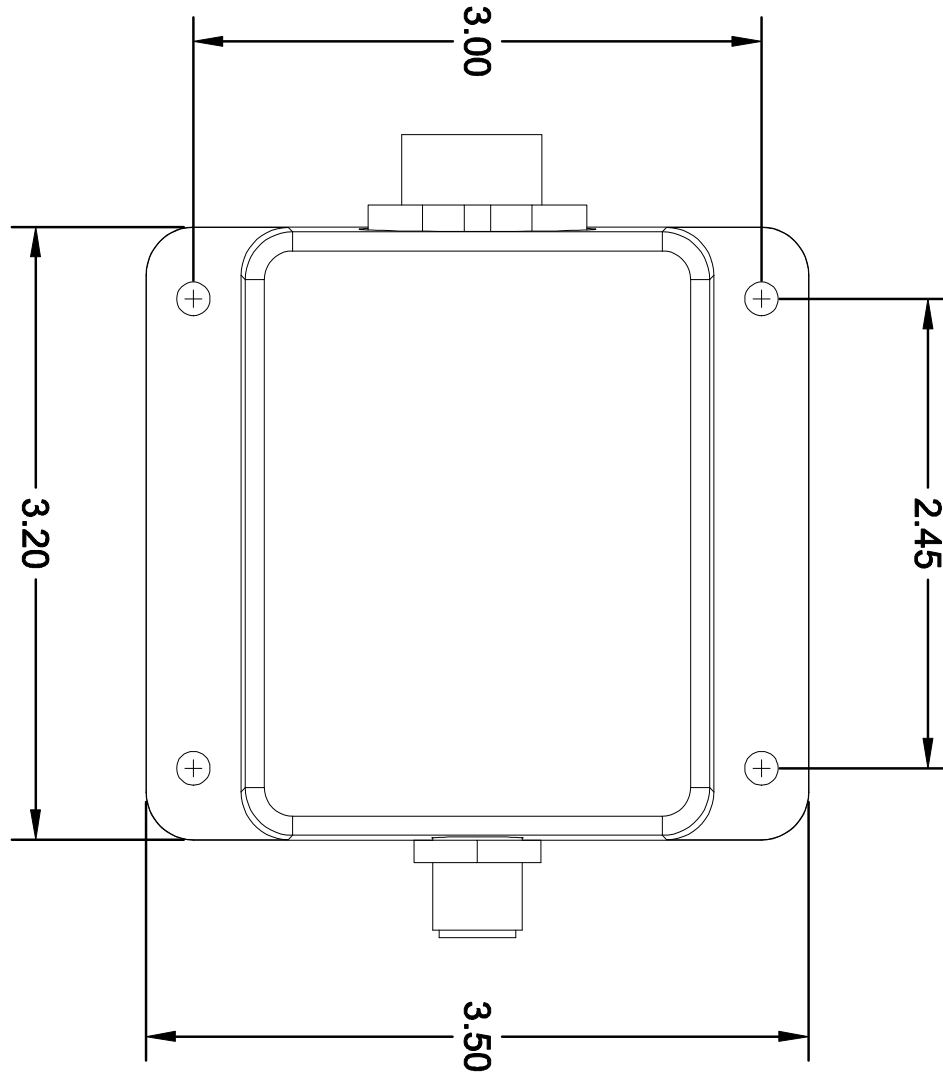

**Figure 4 – Mounting Surface Template**

### **8 Maretron (2 Year) Limited Warranty**

Maretron warrants the USB100 to be free from defects in materials and workmanship for **two (2) years** from the date of original purchase. If within the applicable period any such products shall be proved to Maretron's satisfaction to fail to meet the above limited warranty, such products shall be repaired or replaced at Maretron's option. Purchaser's exclusive remedy and Maretron's sole obligation hereunder, provided product is returned pursuant to the return requirements below, shall be limited to the repair or replacement, at Maretron's option, of any product not meeting the above limited warranty and which is returned to Maretron; or if Maretron is unable to deliver a replacement that is free from defects in materials or workmanship, Purchaser's payment for such product will be refunded. Maretron assumes no liability whatsoever for expenses of removing any defective product or part or for installing the repaired product or part or a replacement therefore or for any loss or damage to equipment in connection with which Maretron's products or parts shall be used. With respect to products not manufactured by Maretron, Maretron's warranty obligation shall in all respects conform to and be limited to the warranty actually extended to Maretron by its supplier. The foregoing warranties shall not apply with respect to products subjected to negligence, misuse, misapplication, accident, damages by circumstances beyond Maretron's control, to improper installation, operation, maintenance, or storage, or to other than normal use or service.

THE FOREGOING WARRANTIES ARE EXPRESSLY IN LIEU OF AND EXCLUDES ALL OTHER EXPRESS OR IMPLIED WARRANTIES, INCLUDING BUT NOT LIMITED TO THE IMPLIED WARRANTIES OF MERCHANTABILITY AND OF FITNESS FOR A PARTICULAR PURPOSE.

Statements made by any person, including representatives of Maretron, which are inconsistent or in conflict with the terms of this Limited Warranty, shall not be binding upon Maretron unless reduced to writing and approved by an officer of Maretron.

IN NO CASE WILL MARETRON BE LIABLE FOR INCIDENTAL OR CONSEQUENTIAL DAMAGES, DAMAGES FOR LOSS OF USE, LOSS OF ANTICIPATED PROFITS OR SAVINGS, OR ANY OTHER LOSS INCURRED BECAUSE OF INTERRUPTION OF SERVICE. IN NO EVENT SHALL MARETRON'S AGGREGATE LIABILITY EXCEED THE PURCHASE PRICE OF THE PRODUCT(S) INVOLVED. MARETRON SHALL NOT BE SUBJECT TO ANY OTHER OBLIGATIONS OR LIABILITIES, WHETHER ARISING OUT OF BREACH OF CONTRACT OR WARRANTY, TORT (INCLUDING NEGLIGENCE), OR OTHER THEORIES OF LAW WITH RESPECT TO PRODUCTS SOLD OR SERVICES RENDERED BY MARETRON, OR ANY UNDERTAKINGS, ACTS OR OMISSIONS RELATING THERETO.

Maretron does not warrant that the functions contained in any software programs or products will meet purchaser's requirements or that the operation of the software programs or products will be uninterrupted or error free. Purchaser assumes responsibility for the selection of the software programs or products to achieve the intended results, and for the installation, use and results obtained from said programs or products. No specifications, samples, descriptions, or illustrations provided Maretron to Purchaser, whether directly, in trade literature, brochures or other documentation shall be construed as warranties of any kind, and any failure to conform with such specifications, samples, descriptions, or illustrations shall not constitute any breach of Maretron's limited warranty.

#### **Warranty Return Procedure:**

To apply for warranty claims, contact Maretron or one of its dealers to describe the problem and determine the appropriate course of action. If a return is necessary, place the product in its original packaging together with proof of purchase and send to an Authorized Maretron Service Location. You are responsible for all shipping and insurance charges. Maretron will return the replaced or repaired product with all shipping and handling prepaid except for requests requiring expedited shipping (i.e. overnight shipments). Failure to follow this warranty return procedure could result in the product's warranty becoming null and void.

Maretron reserves the right to modify or replace, at its sole discretion, without prior notification, the warranty listed above. To obtain a copy of the then current warranty policy, please go to the following web page:

<http://www.maretron.com/company/warranty.php>

## Appendix A

### NMEA 2000® PGN to NMEA 0183 Sentence Translations

#### PGN 126992 (System Time)

The NMEA 2000® System Time PGN is translated to the ZDA NMEA 0183 sentence entitled *Time & Date* as shown in the following table.

NMEA 2000 PGN 126992 – System Time		NMEA 0183 Sentence ZDA – Time & Date	
Field #	Description	Field #	Description
1	SID	1	UTC
2	Source	2	Day, 01 to 31
3	Reserved	3	Month, 01 to 12
4	Date	4	Year
5	Time	5	Null
		6	Null

#### PGN 127245 (Rudder)

The NMEA 2000® Rudder PGN is translated to the RSA NMEA 0183 sentence entitled *Rudder Sensor Angle* as shown in the following table.

NMEA 2000 PGN 127245 – Rudder		NMEA 0183 Sentence RSA – Rudder Sense Angle	
Field #	Description	Field #	Description
1	Rudder Instance	1	Starboard Rudder Sensor
2	Direction Order	2	Starboard Status
3	Reserved	3	Null
4	Angle Order	4	Null
5	Position		
6	Reserved		

#### PGN 127250 (Vessel Heading)

The NMEA 2000® Vessel Heading PGN is translated to either the HDG NMEA 0183 sentence entitled *Heading, Deviation & Variation* or it is translated to the HDT NMEA 0183 sentence entitled *Heading, True* depending on the state of field 5 of the PGN. If field 5 of the PGN indicates “Magnetic”, then the HDG sentence is transmitted; conversely, if field 5 of the PGN indicates “True”, then the HDT sentence is transmitted as shown in the following tables.

NMEA 2000 PGN 127250 – Vessel Heading		NMEA 0183 Sentence HDG – Heading, Deviation & Variation	
Field #	Description	Field #	Description
1	SID	1	Magnetic Sensor Heading
2	Heading Sensor Reading	2	Magnetic Deviation
3	Deviation	3	Deviation E/W
4	Variation	4	Magnetic Variation
5	Heading Sensor Ref.	5	Variation E/W
6	Reserved		

NMEA 2000 PGN 127250 – Vessel Heading		NMEA 0183 Sentence HDT – Heading, True	
Field #	Description	Field #	Description
1	SID	1	Heading
2	Heading Sensor Reading	2	Always Transmitted as “T”
3	Deviation		
4	Variation		
5	Heading Sensor Ref.		
6	Reserved		

## PGN 127251 (Rate of Turn)

The NMEA 2000® Rate of Turn PGN is translated to the ROT NMEA 0183 sentence entitled *Rate of Turn* as shown in the following table.

NMEA 2000 PGN 127251 – Rate of Turn		NMEA 0183 Sentence ROT – Rate of Turn	
Field #	Description	Field #	Description
1	SID	1	Rate of Turn
2	Rate of Turn	2	Always Transmitted as "A"
3	Reserved		

## PGN 127257 (Attitude)

The NMEA 2000® Attitude PGN is translated to a Maretron proprietary NMEA 0183 sentence as shown in the following table.

NMEA 2000 PGN 127257 – Attitude		NMEA 0183 Sentence PMAROUT - Attitude	
Field #	Description	Field #	Description
1	SID	1	Transmitted as "ATT"
2	Yaw	2	Roll
3	Pitch	3	Pitch
4	Roll	4	Yaw
5	Reserved	5	Null
		6	Null
		7	Null
		8	Null
		9	Null

## PGN 127488 (Engine Parameters, Rapid Update)

The NMEA 2000® Engine Parameters, Rapid Update PGN is translated to the RPM NMEA 0183 sentence entitled *Revolutions* and a Maretron proprietary NMEA 0183 sentence as shown in the following table.

NMEA 2000 PGN 127488 – Eng. Params, Rapid Update		NMEA 0183 Sentence RPM – Revolutions	
Field #	Description	Field #	Description
1	Engine Instance	1	Transmitted as "E"
2	Engine Speed	2	Engine Number
3	Engine Boost Pressure	3	Speed, RPM
4	Engine Tilt/Trim	4	Null
5	Reserved	5	Always Transmitted as "A"

NMEA 0183 Sentence PMAREPR – Engine Params., Rapid	
Field #	Description
1	Engine Number
2	Boost Pressure (mbar)
3	Engine Tilt/Trim (%)
4	Always Transmitted as "A"

## PGN 127489 (Engine Parameters, Dynamic)

The NMEA 2000® Engine Parameters, Dynamic PGN is translated to a Maretron proprietary NMEA 0183 sentence as shown in the following table.

NMEA 2000 PGN 127489 – Eng. Params, Dynamic		NMEA 0183 Sentence PMAREPD – Engine Params, Dynam.	
Field #	Description	Field #	Description
1	Engine Instance	1	Engine Number
2	Engine Oil Pressure	2	Engine Oil Press. (mbar)
3	Engine Oil Temp.	3	Engine Oil Temp. (°C)
4	Engine Temp.	4	Engine Temp. (°C)
5	Alternator Potential	5	Alternator Potential (V)
6	Fuel Rate	6	Fuel Rate (lph)
7	Total Engine Hours	7	Total Engine Hours (hrs)
8	Engine Coolant Pressure	8	Coolant Pressure (mbar)
9	Fuel Pressure	9	Fuel Pressure (mbar)
10	Reserved	10	Engine Discrete Status 1
11	Engine Discrete Status 1	11	Engine Discrete Status 2
12	Engine Discrete Status 2	12	Percent Engine Load (%)
13	Percent Engine Load	13	Percent Eng. Torque(%)
14	Percent Engine Torque		

## PGN 127505 (Fluid Level)

The NMEA 2000® Fluid Level PGN is translated to the XDR NMEA 0183 sentence entitled *Transducer Measurement* as shown in the following table.

NMEA 2000 PGN 127505 – Fluid Level		NMEA 0183 Sentence XDR – Transducer Measurement	
Field #	Description	Field #	Description
1	Fluid Instance	1	Transmitted as "V"
2	Fluid Type	2	Amount of Fluid (liters)
3	Fluid Level	3	Transmitted as "M"
4	Tank Capacity	4	Note 1
5	Reserved		

Note 1: Transmitted as "x#y", where "x" is one of "FUEL", "FRESHWATER", "WASTEWATER", "LIVWELL", "OIL", or "BLACKWATER", and y is the fluid instance. For example, for fuel tank #0, this field would contain "FUEL#0".

## PGN 127508 (Battery Status)

The NMEA 2000® Battery Status PGN is translated to the XDR NMEA 0183 sentence entitled *Transducer Measurement* as shown in the following table.

NMEA 2000 PGN 127508 – Battery Status		NMEA 0183 Sentence XDR – Transducer Measurement	
Field #	Description	Field #	Description
1	Battery Instance	1	Transmitted as "U"
2	Battery Potential	2	Battery Potential
3	Battery Current	3	Transmitted as "V"
4	Battery Case Temp.	4	Trans. as "BATVOLTxxx"
5	Reserved	5	Transmitted as "I"
		6	Battery Current
		7	Transmitted as "A"
		8	Trans. as "BATCURRxxx"
		9	Transmitted as "C"
		10	Battery Case Temp.
		11	Transmitted as "C"
		12	Trans. as "BATTEMPxxx"

## PGN 128259 (Speed)

The NMEA 2000® Speed PGN is translated to the VBW NMEA 0183 sentence entitled *Dual Ground / Water Speed* and the VHW NMEA 0183 sentence entitled *Water Speed and Heading* as shown in the following table.

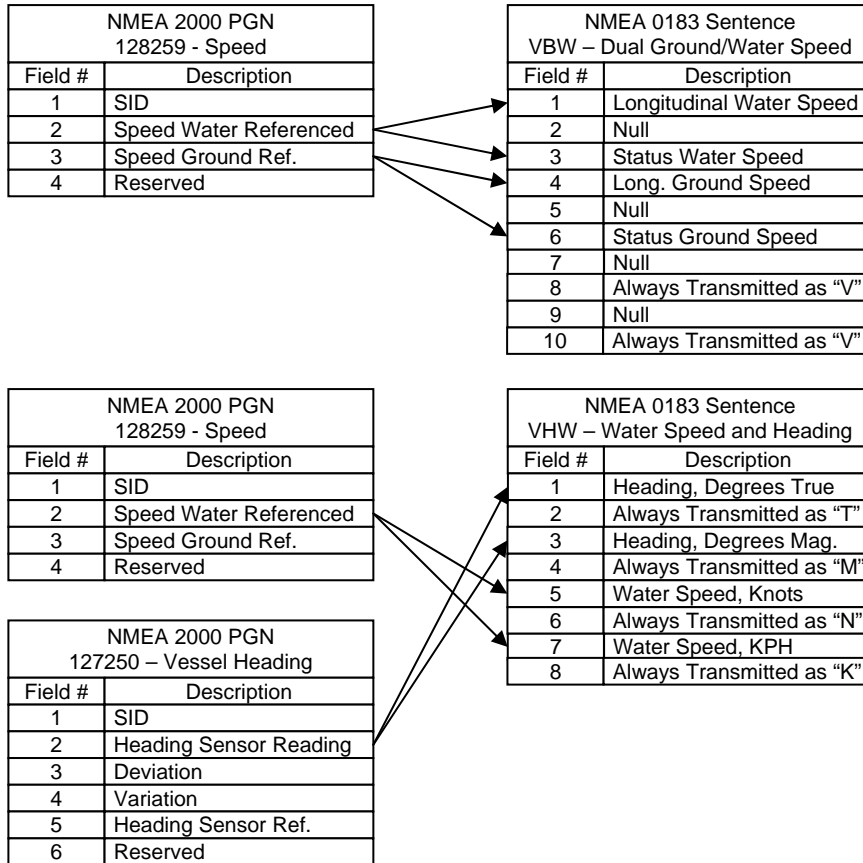

## PGN 128267 (Water Depth)

The NMEA 2000® Water Depth PGN is translated to the DPT NMEA 0183 sentence entitled *Depth* as shown in the following table.

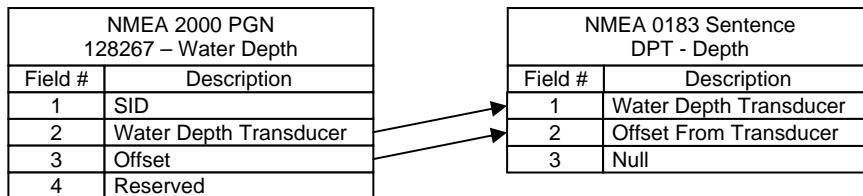

## PGN 128275 (Distance Log)

The NMEA 2000® Distance Log PGN is translated to the VLW NMEA 0183 sentence entitled *Dual Ground / Water Distance* as shown in the following table.

NMEA 2000 PGN 128275 – Distance Log		NMEA 0183 Sentence VLW – Dual Ground/Water Distance	
Field #	Description	Field #	Description
1	Measurement Date	1	Total Cumulative Distance
2	Measurement Time	2	Always Transmitted as "N"
3	Total Cumulative Distance	3	Distance Since Last Reset
4	Distance Since Last Reset	4	Always Transmitted as "N"
		5	Null
		6	Always Transmitted as "N"
		7	Null
		8	Always Transmitted as "N"

## PGN 129026 (COG & SOG, Rapid Update)

The NMEA 2000® COG & SOG, Rapid Update PGN is translated to the VTG NMEA 0183 sentence entitled *Course Over Ground and Ground Speed* as shown in the following table. Note that the VTG sentence "Mode Indicator" field is obtained from the GNSS Position Data PGN given that the SID fields for both PGNs match.

NMEA 2000 PGN 129026 – COG & SOG, Rapid Update		NMEA 0183 Sentence VTG – COG and SOG	
Field #	Description	Field #	Description
1	SID	1	Course Over Ground
2	COG Reference	2	Always Transmitted as "T"
3	Reserved	3	Course Over Ground
4	Course Over Ground	4	Always Transmitted as "M"
5	Speed Over Ground	5	Speed Over Ground
6	Reserved	6	Always Transmitted as "N"
		7	Speed Over Ground
		8	Always Transmitted as "K"
		9	Mode Indicator

NMEA 2000 PGN 129029 – GNSS Position Data		NMEA 0183 Sentence GGA – GPS Fix Data	
Field #	Description	Field #	Description
1	SID	1	UTC of Position
2	Position Date	2	Latitude
3	Position Time	3	N/S
4	Latitude	4	Longitude
5	Longitude	5	E/W
6	Altitude	6	GPS Quality Indicator
7	Type of System	7	# of Satellites in Use
8	Method, GNSS	8	HDOP
9	Integrity	9	Altitude
10	Reserved	10	Always Transmitted as "M"
11	Number of SVs	11	Geoidal Separation
12	HDOP	12	Always Transmitted as "M"
13	PDOP	13	Age DGNSS Correction
14	Geoidal Separation	14	Reference Station ID
15	# of Reference Stations		
16	Reference Station Type "1"		
17	Reference Station ID "1"		
18	Age DGNSS Correction "1"		
19	Reference Station Type "n"		
20	Reference Station ID "n"		
21	Age DGNSS Correction "n"		

## PGN 129029 (GNSS Position Data)

The NMEA 2000® GNSS Position Data PGN is translated to either the GGA NMEA 0183 sentence entitled *GPS Fix Data* as shown in the previous section or it is translated to the GNS NMEA 0183 sentence entitled *GNSS Fix Data* depending on the state of field 7 of the PGN. If field 7 of the PGN indicates “GPS”, then the GGA sentence is transmitted (see table under PGN 129026), if field 7 indicates “GLONASS”, then the GNS sentence is transmitted as shown in the following table.

NMEA 2000 PGN 129029 – GNSS Position Data		NMEA 0183 Sentence GNS – GNSS Fix Data	
Field #	Description	Field #	Description
1	SID	1	UTC of Position
2	Position Date	2	Latitude
3	Position Time	3	N/S
4	Latitude	4	Longitude
5	Longitude	5	E/W
6	Altitude	6	Mode Indicator
7	Type of System	7	# of Satellites in Use
8	Method, GNSS	8	HDOP
9	Integrity	9	Altitude
10	Reserved	10	Geoidal Separation
11	Number of SVs	11	Age DGNSS Correction
12	HDOP	12	Reference Station ID
13	PDOP		
14	Geoidal Separation		
15	# of Reference Stations		
16	Reference Station Type “1”		
17	Reference Station ID “1”		
18	Age DGNSS Correction “1”		
19	Reference Station Type “n”		
20	Reference Station ID “n”		
21	Age DGNSS Correction “n”		

The NMEA 2000® GNSS Position Data PGN is also translated to the GLL NMEA 0183 sentence entitled *Geographic Position – Latitude/Longitude* as shown in the following table.

NMEA 2000 PGN 129029 – GNSS Position Data		NMEA 0183 Sentence GLL – Geographic Position – Lat/Lon	
Field #	Description	Field #	Description
1	SID	1	Latitude
2	Position Date	2	N/S
3	Position Time	3	Longitude
4	Latitude	4	E/W
5	Longitude	5	UTC of Position
6	Altitude	6	Status
7	Type of System	7	Mode Indicator
8	Method, GNSS		
9	Integrity		
10	Reserved		
11	Number of SVs		
12	HDOP		
13	PDOP		
14	Geoidal Separation		
15	# of Reference Stations		
16	Reference Station Type “1”		
17	Reference Station ID “1”		
18	Age DGNSS Correction “1”		
19	Reference Station Type “n”		
20	Reference Station ID “n”		
21	Age DGNSS Correction “n”		

## PGN 129033 (Time & Date)

The NMEA 2000® Time & Date PGN is translated to the ZDA NMEA 0183 sentence entitled *Time & Date* as shown in the following table.

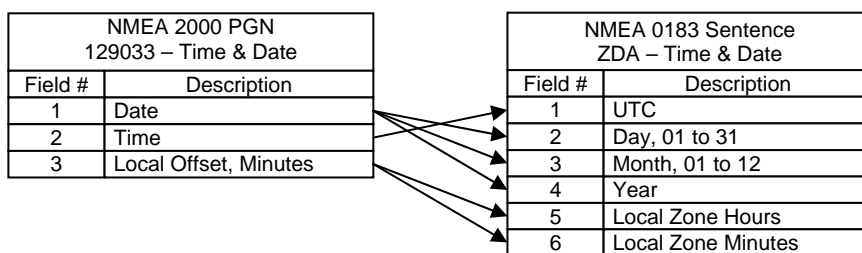

## PGN 129539 (GNSS DOPs)

The NMEA 2000® GNSS DOPs PGN is translated to the GSA NMEA 0183 sentence entitled *GNSS DOP and Active Satellites* as shown in the following table. Note that the GSA sentence satellite ID numbers fields are obtained from the GNSS Sats in View PGN given that the SID fields for both PGNs match.

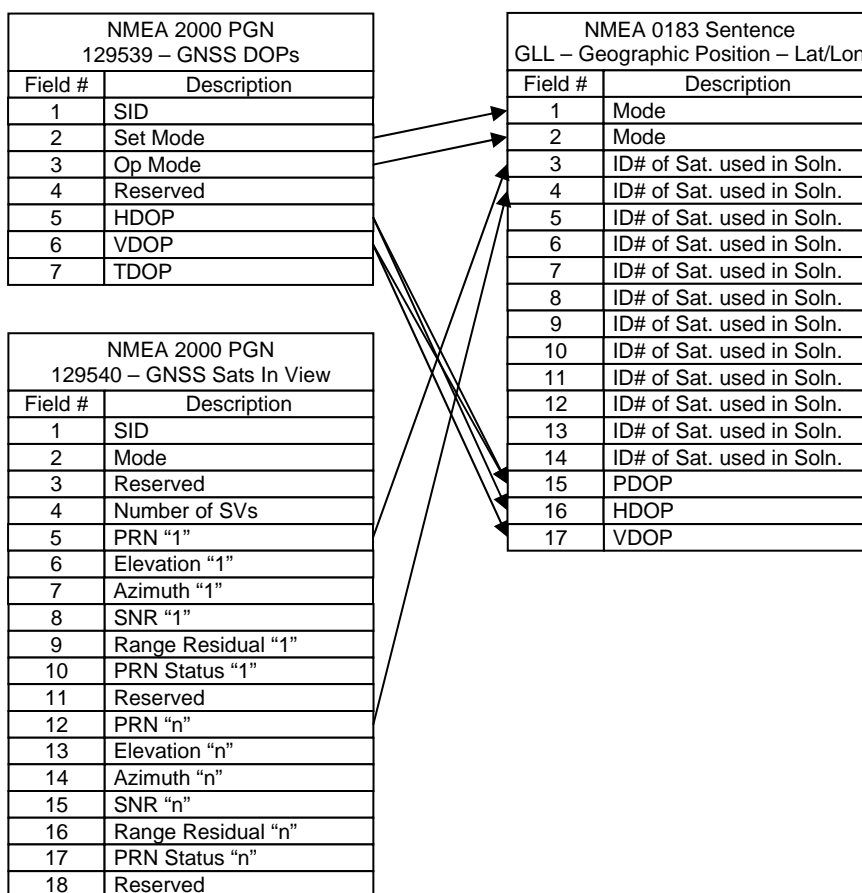

# USB100 User's Manual

## PGN 129540 (GNSS Sats in View)

The NMEA 2000® GNSS Sats in View PGN is translated to the GSV NMEA 0183 sentence entitled *GNSS Satellites in View* as shown in the following table.

NMEA 2000 PGN 129540 – GNSS Sats In View		NMEA 0183 Sentence GSV – GNSS Satellites In View	
Field #	Description	Field #	Description
1	SID	1	Total Numb. of Sentences
2	Mode	2	Sentence Number
3	Reserved	3	Total # of Satellites in View
4	Number of SVs	4	Satellite #1 Id Number
5	PRN "1"	5	Elevation #1
6	Elevation "1"	6	Azimuth #1
7	Azimuth "1"	7	SNR #1
8	SNR "1"	8	Satellite #2 ID Number
9	Range Residual "1"	9	Elevation #2
10	PRN Status "1"	10	Azimuth #2
11	Reserved	11	SNR #2
12	PRN "n"		•
13	Elevation "n"		•
14	Azimuth "n"		•
15	SNR "n"		•
16	Range Residual "n"		
17	PRN Status "n"		
18	Reserved		
	•		
	•		
	•		

The NMEA 2000® GNSS Sats in View PGN is also translated to the GSA NMEA 0183 sentence entitled *GNSS DOP and Active Satellites* as shown in the following table.

NMEA 2000 PGN 129539 – GNSS DOPs		NMEA 0183 Sentence GSA - GNSS DOP & Active Satellites	
Field #	Description	Field #	Description
1	SID	1	Mode
2	Set Mode	2	Mode
3	Op Mode	3	ID# of Sat. used in Soln.
4	Reserved	4	ID# of Sat. used in Soln.
5	HDOP	5	ID# of Sat. used in Soln.
6	VDOP	6	ID# of Sat. used in Soln.
7	TDOP	7	ID# of Sat. used in Soln.
		8	ID# of Sat. used in Soln.
		9	ID# of Sat. used in Soln.
		10	ID# of Sat. used in Soln.
		11	ID# of Sat. used in Soln.
		12	ID# of Sat. used in Soln.
		13	ID# of Sat. used in Soln.
		14	ID# of Sat. used in Soln.
		15	PDOP
		16	HDOP
		17	VDOP

NMEA 2000 PGN 129540 – GNSS Sats In View	
Field #	Description
1	SID
2	Mode
3	Reserved
4	Number of SVs
5	PRN "1"
6	Elevation "1"
7	Azimuth "1"
8	SNR "1"
9	Range Residual "1"
10	PRN Status "1"
11	Reserved
12	PRN "n"
13	Elevation "n"
14	Azimuth "n"
15	SNR "n"
16	Range Residual "n"
17	PRN Status "n"
18	Reserved

## PGN 130306 (Wind Data)

The NMEA 2000® Wind Data PGN is translated to either the MWD NMEA 0183 sentence entitled *Wind Direction and Speed* or it is translated to the MWV NMEA 0183 sentence entitled *Wind Speed & Angle* depending on the state of field 4 of the PGN. If field 4 of the PGN indicates “True (referenced to North)” or “Magnetic”, then the MWD sentence is transmitted, if field 4 indicates “Apparent” or “True (referenced to boat)”, then the MWV sentence is transmitted as shown in the following tables.

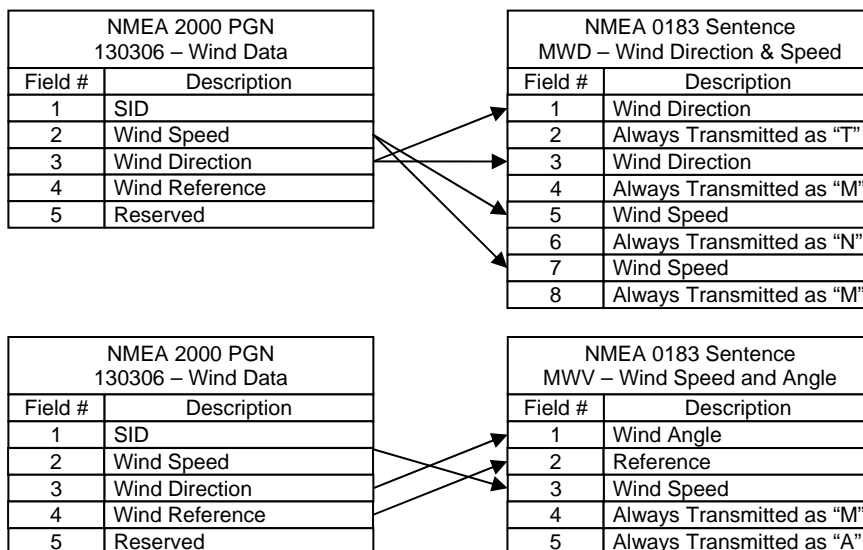

## PGN 130310 (Environmental Parameters)

The NMEA 2000® Environmental Parameters PGN is translated to the MTW NMEA 0183 sentence entitled *Water Temperature* as shown in the following table.

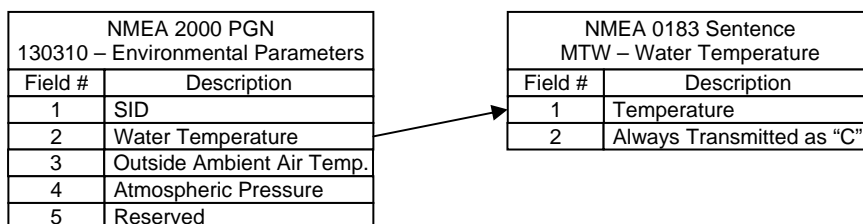

The NMEA 2000® Environmental Parameters PGN is also translated to the XDR NMEA 0183 sentence entitled *Transducer Measurement* as shown in the following table.

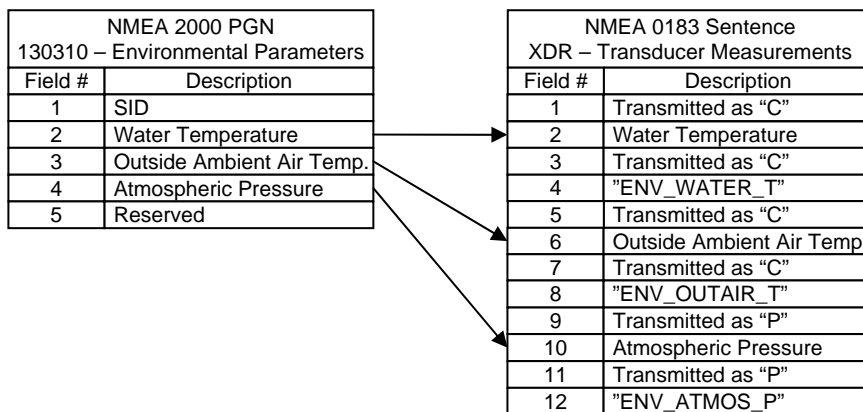

## PGN 130311 (Environmental Parameters)

The NMEA 2000® Environmental Parameters PGN is translated to the MTW NMEA 0183 sentence entitled *Water Temperature* as shown in the following table.

NMEA 2000 PGN 130311 – Environmental Parameters		NMEA 0183 Sentence MTW – Water Temperature	
Field #	Description	Field #	Description
1	SID	1	Temperature
2	Temperature Instance	2	Always Transmitted as "C"
3	Humidity Instance		
4	Temperature		
5	Humidity		
6	Atmospheric Pressure		

The NMEA 2000® Environmental Parameters PGN is also translated to the XDR NMEA 0183 sentence entitled *Transducer Measurement* as shown in the following table.

NMEA 2000 PGN 130311 – Environmental Parameters		NMEA 0183 Sentence XDR – Transducer Measurements	
Field #	Description	Field #	Description
1	SID	1	Transmitted as "C"
2	Temperature Instance	2	Note 1
3	Humidity Instance	3	Transmitted as "C"
4	Temperature	4	Note 2
5	Humidity	5	Transmitted as "P"
6	Atmospheric Pressure	6	Atmospheric Pressure
		7	Transmitted as "P"
		8	"ENV_ATMOS_P"
		9	Transmitted as "P"
		10	Note 3
		11	Transmitted as "H"
		12	Note 4

Note 1: Sea Temperature, Outside Temperature, Inside Temperature, Engine Room Temperature, or Main Cabin Temperature, depending on the contents of the 130311 PGN.

Note 2: Transmitted as "ENV\_SEA\_T", "ENV\_OUTSIDE\_T", "ENV\_INSIDE\_T", "ENV\_EROOM\_T", or "ENV\_MCABIN\_T", depending on the contents of the 130311 PGN.

Note 3: Inside Humidity or Outside Humidity, depending on the contents of the 130311 PGN.

Note 4: Transmitted as "ENV\_INSIDE\_H" or "ENV\_OUTSIDE\_H" depending on the contents of the 130311 PGN.

## PGN 130576 (Small Craft Status)

The NMEA 2000® Small Craft Status PGN is translated to the XDR NMEA 0183 sentence entitled *Transducer Measurement* as shown in the following table.

NMEA 2000 PGN 130576 – Small Craft Status		NMEA 0183 Sentence XDR – Transducer Measurements	
Field #	Description	Field #	Description
1	Port Trim Tab	1	Transmitted as "G"
2	Starboard Trim Tab	2	Port Trim Tab
3	Reserved	3	Null
		4	"PORT_TRIM"
		5	Transmitted as "G"
		6	Starboard Trim Tab
		7	Null
		8	"STBD_TRIM"

## Appendix B NMEA 0183 Sentence to NMEA 2000® PGN Translations

### RMB (Recommended Minimum Navigation Information)

The RMB sentence is translated into three different NMEA 2000® PGNs as shown in the following tables.

NMEA 0183 Sentence RMB – Recommended Min. Nav. Info.		NMEA 2000 PGN 129283 – Cross Track Error	
Field #	Description	Field #	Description
1	Data Status	1	SID
2	Cross Track Error	2	XTE Mode
3	Direction to Steer	3	Reserved
4	Origin Waypoint ID	4	Navigation Terminated
5	Destination Waypoint ID	5	XTE
6	Destination WP Latitude	6	Reserved
7	Destination WP Lat. N/S		
8	Destination WP Longitude		
9	Destination WP Long. E/W		
10	Range to Destination		
11	Bearing to Destination		
12	Dest. Closing Velocity		
13	Arrival Status		
14	Mode Indicator		

NMEA 0183 Sentence RMB – Recommended Min. Nav. Info.		NMEA 2000 PGN 129284 – Navigation Data	
Field #	Description	Field #	Description
1	Data Status	1	SID
2	Cross Track Error	2	Distance to Dest. WP
3	Direction to Steer	3	Course/Bearing Ref.
4	Origin Waypoint ID	4	Perpendicular Crossed
5	Destination Waypoint ID	5	Arrival Circle Entered
6	Destination WP Latitude	6	Calculation Type
7	Destination WP Lat. N/S	7	ETA Time
8	Destination WP Longitude	8	ETA Date
9	Destination WP Long. E/W	9	Bearing, Origin to Dest.
10	Range to Destination	10	Bearing, Position to Dest.
11	Bearing to Destination	11	Origin WP Number
12	Dest. Closing Velocity	12	Destination WP Number
13	Arrival Status	13	Destination WP Latitude
14	Mode Indicator	14	Destination WP Longitude
		15	WP Closing Velocity

NMEA 0183 Sentence BOD – Bearing – Origin to Destination	
Field #	Description
1	Bearing True
2	True
3	Bearing Magnetic
4	Magnetic
5	Destination Waypoint ID
6	Origin Waypoint ID

NMEA 0183 Sentence RMB – Recommended Min. Nav. Info.	
Field #	Description
1	Data Status
2	Cross Track Error
3	Direction to Steer
4	Origin Waypoint ID
5	Destination Waypoint ID
6	Destination WP Latitude
7	Destination WP Lat. N/S
8	Destination WP Longitude
9	Destination WP Long. E/W
10	Range to Destination
11	Bearing to Destination
12	Dest. Closing Velocity
13	Arrival Status
14	Mode Indicator

NMEA 2000 PGN 129285 – Navigation – Route/WP Info	
Field #	Description
1	Start RPS#
2	nItems
3	Data Base ID
4	Route ID
5	Nav. Direction in Route
6	Suppl. Route/WP Data
7	Reserved
8	Route Name
9	Reserved
10	WPID
11	WP Name
12	WP Latitude
13	WP Longitude
14	Repeat

