

EMS100 Analog Engine Monitoring System



Maretron's EMS100 plugs directly into engine wiring harnesses and converts analog signals such as water temperature and oil pressure to the new marine digital interface (NMEA 2000®). Critical engine data is then distributed throughout the vessel over a single cable where it can be monitored by any NMEA 2000® compatible display.

The EMS100 is compatible with existing instrument panels and key switches so you don't need to remove them while upgrading to newer digital technology. For new installations, the EMS100 and a compatible NMEA 2000® display can replace the traditional analog instrument panel.



The EMS100 provides these functions:

- Tachometer
- Engine Hours
- Coolant Water Temperature
- Engine Oil Pressure
- Boost Pressure
- Charging Voltage
- Drive Trim
- Fuel Filter Alarm
- Boost Alarm
- Coolant Water Level Alarm
- Engine Oil Pressure Alarm
- Exhaust (Salt Water Flow) Alarm
- Coolant Water Temperature Alarm

The EMS100 is compatible with these Yanmar engines

(other engines supported soon, check our web page www.maretron.com):

- GM Series
- YM Series
- JH Series
- LH Series
- LP Series
- LY Series

Products

PART NUMBER	DESCRIPTION
EMS100-01	Analog Engine Monitoring System
EMSYMR01	Yanmar Harness

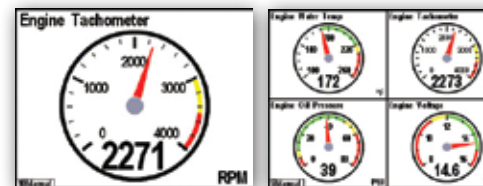
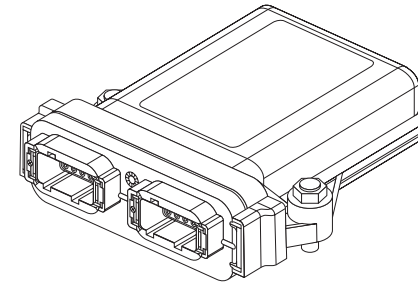
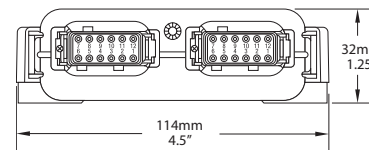
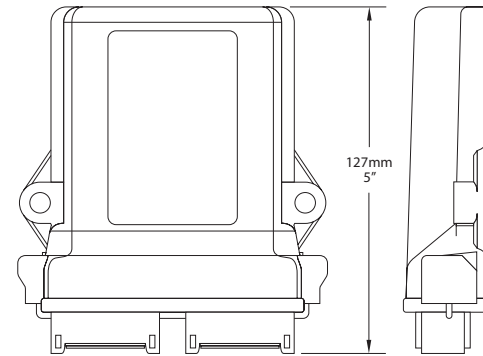

DSM250 Screen Shots

Specifications

Parameter	Type	Comment
Tachometer	Analog/Digital Input	Configurable by # of Teeth
Engine Hours	Logged with Key On	Stored Indefinitely in Non-Volatile Memory
Oil Pressure	Analog Input	Sensor Voltage Monitor/Sensitize
Coolant Water Temp	Analog Input	Sensor Voltage Monitor/Sensitize
Boost Pressure	Analog Input	Sensor Voltage Monitor/Sensitize
Drive Trim Angle	Analog Input	Sensor Voltage Monitor/Sensitize
Charging Voltage	Alarm/Switch Input	
Lube Oil Filter Alarm	Alarm/Switch Input	
Boost Pressure Alarm	Alarm/Switch Input	
Coolant Water Temperature Alarm	Alarm/Switch Input	
Oil Pressure Alarm	Alarm/Switch Input	
Exhaust (Salt Water Flow) Alarm	Alarm/Switch Input	
Clutch Oil Pressure Alarm	Alarm/Switch Input	
Diesel Preheat Alarm	Alarm/Switch Input	
Diesel Preheat Alarm	Alarm/Switch Input	

Certifications

Standard	Comment
NMEA 2000® Standard	Level A
Maritime Navigation and Radio Communication Equipment & Systems	IEC 61162-3
Maritime Navigation and Radio Communication Equipment & Systems	IEC 60945
FCC and CE mark	Electromagnetic Compatibility

NMEA 2000® Parameter Group Numbers (PGNs)

Description	PGN #	PGN Name	Default Rate
Periodic Data PGNs	127488	Engine Parameters, Rapid Update	10 times/second
	127489	Engine Parameters, Dynamic	1 time/second
Response to Request PGNs	126464	PGN List (Transmit and Receive)	N/A
	126996	Product Information	N/A
	126998	Configuration Information	N/A
	059392	ISO Acknowledge	N/A
Protocol PGNs	059904	ISO Request	N/A
	060416	ISO Transport Protocol, Connection Management	N/A
	060160	ISO Transport Protocol, Data Transfer	N/A
	060928	ISO Address Claim	N/A
	065240	ISO Address Command	N/A
	126208	NMEA Request/Command/Acknowledge	N/A
Maretron Proprietary PGNs	126720	Configuration	N/A

Electrical

Parameter	Value	Comment
Operating Voltage	9 to 16 Volts	NMEA Interface
	9 to 32 Volts	Engine Interface
Power Consumption	<150mA	From Battery
Load Equivalence Number (LEN)	1	NMEA 2000® Spec. (1LEN = 50 mA)
Reverse Battery Protection	Yes	Indefinitely
Load Dump Protection	Yes	Energy Rated per SAE J1113

Mechanical

Parameter	Value	Comment
Size	5" x 4.5" x 1.25" (127mm x 114mm x 32mm)	Excluding Wiring Harness
Weight	12 Oz. (340 g)	Excluding Wiring Harness

Environmental

Parameter	Value
IEC 60945 Classification	Exposed
Degree of Protection	IP68
Operating Temperature	-25°C to 55°C
Storage Temperature	-40°C to 70°C
Relative Humidity	93%RH @ 40° per IEC60945-8.2
Vibration	2-13.2Hz @ ±1mm, 13.2-100Hz @ 7m/s² per IEC 60945-8.7
Rain and Spray	12.5mm Nozzle @ 100liters/min from 3m for 30min per IEC 60945-8.8
Solar Radiation	Ultraviolet B, A, Visible, and Infrared per IEC 60945-8.10
Corrosion (Salt Mist)	4 times 7days @ 40°C, 95%RH after 2 hour Salt Spray Per IEC 60945-8.12
Electromagnetic Emission	Conducted and Radiated Emission per IEC 60945-9
Electromagnetic Immunity	Conducted, Radiated, Supply, and ESD per IEC 60945-10
Safety Precautions	Dangerous Voltage, Electromagnetic Radio Frequency per IEC 60945-12